

Pivato
le porte

linea | legno
LACCATI E LEGNI

Indice

Index

Galleria fotografica / <i>Photo gallery</i>	5
Maniglie scavate / <i>Carved handles</i>	145
Guida alla scelta / <i>Choice guide</i>	159
Lo stile / <i>The style</i>	162
Il modello / <i>The model</i>	166
Finiture e colori / <i>Finishes and colours</i>	183
Aperture / <i>Openings</i>	194
Collezioni / <i>Collections</i>	207
Vivace con stipite su misura e coprifilo telescopico	212
Opera 50	218
Vivace con stipite su misura	224
Dinamica	230
Unica	236
Inversa	242
Leggera	248
Scorrevoli Special	254
Plus delle porte Pivato / <i>Plus of Pivato's doors</i>	275
Complementi / <i>Complements</i>	301
L'Azienda / <i>The Company</i>	311
Inserto illustrato / <i>Illustrated insert</i>	319

Arreda

Furnish

Entra

Enter

A dark grey door with a silver handle and a white geometric pattern on the right side. The pattern consists of a grid of white lines forming a series of diamonds and squares. The door is slightly ajar, revealing a dark interior.

Vivi

Live

Galleria fotografica
Photo gallery

Stile / Style

LISCIA / *SMOOTH*



STILE LISCIA / SMOOTH STYLE**model 106**frassino laccato spazzolato /
brushed lacquered ash wood

tortora

al soffitto / *to ceiling***Collection Opera50***Design Michele Marcon*MODELLO DEPOSITATO / *REGISTERED PATTERN*

**STILE LISCIA /
SMOOTH STYLE**

model 105

olmo brandy spazzolato /
brushed brandy elm

Design Michele Marcon

MODELLO DEPOSITATO /
REGISTERED PATTERN



**STILE LISCIA /
SMOOTH STYLE**

model 107

frassino laccato spazzolato /
brushed lacquered ash wood
sabbia

Design Michele Marcon

MODELLO DEPOSITATO /
REGISTERED PATTERN



**STILE LISCIA /
SMOOTH STYLE****model 107**rovere grigio spazzolato /
*brushed grey oak***Collection Unica***Design Michele Marcon*

MODELLO DEPOSITATO / REGISTERED PATTERN







**STILE LISCIA /
SMOOTH STYLE
model 103**

frassino laccato spazzolato /
brushed lacquered ash wood
ghiaia



**STILE LISCIA /
SMOOTH STYLE
model 101**

rovere bianco spazzolato /
brushed white oak
tutt'altezza /
full height

Collection Unica

**STILE LISCIA /
SMOOTH STYLE**
model 128

rovere grigio spazzolato /
brushed gray oak



**STILE LISCIA /
SMOOTH STYLE**
model 129

rovere bianco spazzolato /
brushed white oak



**STILE LISCIA /
SMOOTH STYLE**

model 129

olmo brandy spazzolato /
brushed brandy elm

tutt'altezza / *full height*

**Collection Scorrevoli Special
Alchemy**







**STILE LISCIA /
SMOOTH STYLE**

model 114

olmo brandy spazzolato /
brushed brandy elm

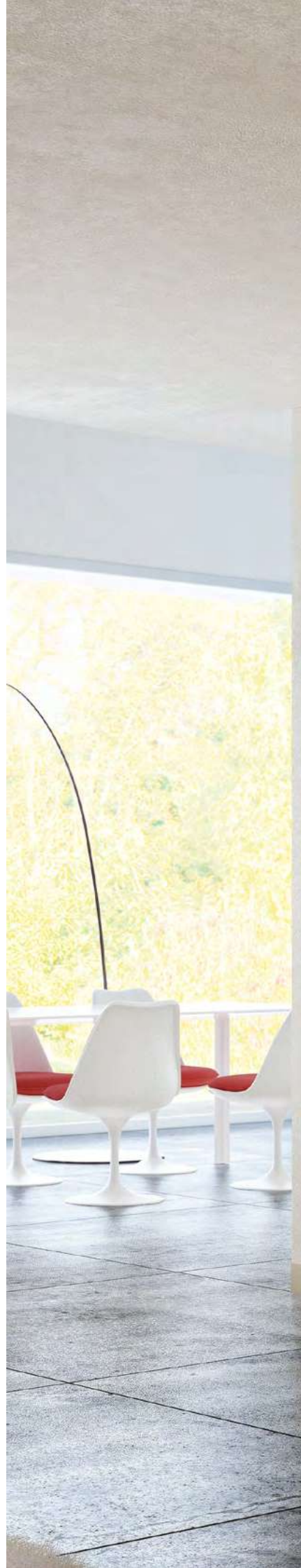

**STILE LISCIA /
SMOOTH STYLE**

model 114

rovere bianco spazzolato /
brushed white oak

Collection Inversa





**STILE LISCIA /
SMOOTH STYLE**
model 115

olmo brandy spazzolato /
brushed brandy elm

**Collezione Vivace con stipite su misura /
Collection Vivace with custom-made jamb**



**STILE LISCIA /
SMOOTH STYLE
model 115**

rovere grigio spazzolato /
brushed gray oak



**STILE LISCIA /
SMOOTH STYLE
model 115**

rovere bianco spazzolato /
brushed white oak



**STILE LISCIA /
SMOOTH STYLE**

model 122

rovere grigio spazzolato /
brushed gray oak

apertura Silenzio /
Silenzio opening

Collection Unica





**STILE LISCIA /
SMOOTH STYLE**

model 122

yellow pine spazzolato /
brushed yellow pine

bianco Pivato

al soffitto / *to ceiling*

Collection Dinamica





**STILE LISCIA /
SMOOTH STYLE
model 122**

frassino laccato spazzolato /
brushed lacquered ash wood
sabbia



**STILE LISCIA /
SMOOTH STYLE
model 124**

rovere grigio spazzolato /
brushed gray oak



Stile / *Style*

**INSERTI IN
ACCIAIO /
STEEL
INSERTS**



**STILE INSERTI IN ACCIAIO /
STEEL INSERTS STYLE**

model 135

rovere bianco spazzolato /
brushed white oak
tutt'altezza / *full height*

Collection Inversa







**STILE INSERTI IN ACCIAIO /
STEEL INSERTS STYLE**

model 133

frassino laccato spazzolato /
brushed lacquered ash wood

ghiaia

scorrevole esterno muro /
external sliding door

tutt'altezza / *full height*

Collection Dinamica

Stile / Style

INCISA / *ENGRAVED*



**STILE INCISA /
ENGRAVED STYLE**

**Serie Orbita /
Orbita Series
model 442**

laccato opaco /
matt lacquered

basalto

h. 3,00 m

Collection Leggera

Design Michele Marcon





**STILE INCISA /
ENGRAVED STYLE**

**Serie Orbita /
Orbita Series**

model 442

laccato opaco /
matt lacquered
canapa

Design Michele Marcon

DETTAGLI

La geometria obliqua delle incisioni rende il design della porta dinamico: uno studio concettuale che si abbina bene alle carte da parati in stile metafisico.

DETAILS

The oblique geometry of the engravings makes the room dynamic and design-oriented: it is a conceptual study that goes well with metaphysical style wallpapers.



**STILE INCISA /
ENGRAVED STYLE**

**Serie Orbita /
Orbita Series
model 443**

laccato opaco /
matt lacquered

ardesia

h. 2,64 m

**Collection Scorrevoli Special
Alchemy**

Design Michele Marcon









**STILE INCISA /
ENGRAVED STYLE**

**Serie Orbita /
Orbita Series**

model 443

laccato opaco /
matt lacquered
cashmere

Design Michele Marcon

DETTAGLI

L'orbita descritta dal decoro inciso diventa protagonista della porta. Il design coordinato tra la porta e l'ambiente circostante crea un effetto di continuità di sicuro impatto scenico.

DETAILS

The orbit described by the engraved decoration becomes the protagonist of the door. The coordinated design between the door and its surroundings creates an effect of continuity with great scenic impact.



STILE INCISA / ENGRAVED STYLE
Serie Orbita / Orbita Series
model 440
laccato opaco / *matt lacquered*
cashmere
scorrevole interno muro / *inner wall sliding door*
h. 2,10 m

Collezione Vivace con stipite su misura e coprifilo telescopico /
Collection Vivace with custom-made jamb and telescopic casing



**STILE INCISA /
ENGRAVED STYLE**

**Serie Orbita /
Orbita Series**

model 440

*laccato opaco /
matt lacquered*

cashmere

*battente /
hinged door*

h. 2,10 m

**Collezione Vivace con
stipite su misura e coprifilo
telescopico /**

***Collection Vivace with
custom-made jamb and
telescopic casing***

Design Michele Marcon





**STILE INCISA /
ENGRAVED STYLE**

**Serie Orbita /
Orbita Series
model 440**

laccato opaco /
matt lacquered
ardesia

Design Michele Marcon

DETTAGLI

Un segno minimale percorre l'anta nella sua larghezza, vira attorno alla maniglia e infine scarica a terra la linea slanciando il design della porta stessa. L'ortogonalità del decoro esprime rigore formale e ricerca di minimalismo.

DETAILS

A minimalist sign runs across the width of the door leaf, turns around the handle and finally unloads the lines to the ground, soaring the design of the door itself. The orthogonality of the design expresses formal rigour and desire for minimalism.





**STILE INCISA /
ENGRAVED STYLE**

**Serie Orbita /
Orbita Series
model 441**

*laccato opaco /
matt lacquered*

canapa

*rototraslante /
pivot sliding door*

h. 2,40 m

Collection Dinamica
*coprifilo dritto /
straight casing*

Design Michele Marcon





**STILE INCISA /
ENGRAVED STYLE**

**Serie Orbita /
Orbita Series**

model 441

laccato opaco /
matt lacquered
basalto

Design Michele Marcon

DETTAGLI

L'orbita descritta dal decoro inciso diventa protagonista della porta. Il design coordinato tra la porta e l'ambiente circostante crea un effetto di continuità di sicuro impatto scenico.

DETAILS

The orbit described by the engraved decoration becomes the protagonist of the door. The coordinated design between the door and its surroundings creates an effect of continuity with great scenic impact.



**STILE INCISA /
ENGRAVED STYLE**

model 409

*laccato opaco /
matt lacquered*

corda

*porta battente a due ante /
two leaves hinged door*

*tutt'altezza /
full height*

Collection Unica

Design Michele Marcon

MODELLO DEPOSITATO / REGISTERED PATTERN

**STILE INCISA /
ENGRAVED STYLE**

model 408

laccato opaco /
matt lacquered
agata



**STILE INCISA /
ENGRAVED STYLE**

model 410

laccato opaco /
matt lacquered
muschio

Design Michele Marcon

MODELLO DEPOSITATO /
REGISTERED PATTERN

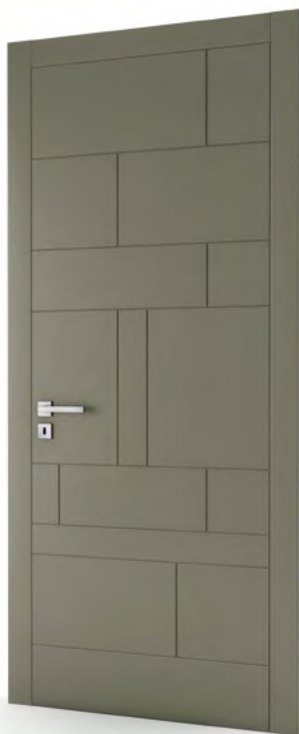

**STILE INCISA /
ENGRAVED STYLE**

model 409

laccato opaco /
matt lacquered

perla

tutt'altezza / *full height*

Collection Unica

Design Michele Marcon

MODELLO DEPOSITATO / REGISTERED PATTERN





STILE INCISA / ENGRAVED STYLE

model 405

laccato opaco / *matt lacquered*

ghiaia

tutt'altezza / *full height*

**Collection Scorrevoli Special
Light**

Design Michele Marcon

MODELLO DEPOSITATO / REGISTERED PATTERN



**STILE INCISA /
ENGRAVED STYLE**
model 406

laccato opaco / *matt lacquered*
perla

Design Michele Marcon

MODELLO DEPOSITATO /
REGISTERED PATTERN



**STILE INCISA /
ENGRAVED STYLE**
model 407

laccato opaco / *matt lacquered*
sabbia

Design Michele Marcon

MODELLO DEPOSITATO /
REGISTERED PATTERN





**STILE INCISA /
ENGRAVED STYLE**

model 404

laccato opaco /
matt lacquered

avorio

Collection Unica

Design Michele Marcon

MODELLO DEPOSITATO / REGISTERED PATTERN





**STILE INCISA /
ENGRAVED STYLE**

model 157

*laccato opaco /
matt lacquered*

sabbia

Collection Inversa

**STILE INCISA /
ENGRAVED STYLE**

model 147

yellow pine laccato spazzolato /
brushed lacquered yellow pine wood

beige

cabina armadio /
walk-in closet

Collection Dinamica

Design Michele Marcon

MODELLO DEPOSITATO /
REGISTERED PATTERN





**STILE INCISA /
ENGRAVED STYLE**

model 143

frassino laccato spazzolato /
brushed lacquered ash wood
ghiaia



**STILE INCISA /
ENGRAVED STYLE**

model 144

laccato opaco /
matt lacquered
cadetto

**STILE INCISA /
ENGRAVED STYLE**

model 140

laccato opaco /
matt lacquered
tortora



**STILE INCISA /
ENGRAVED STYLE**

model 142

frassino laccato spazzolato /
brushed lacquered ash wood
sabbia



**STILE INCISA /
ENGRAVED STYLE**

model 141

*frassino laccato spazzolato /
brushed lacquered ash wood*

panna

Collection Dinamica

Stile / Style

**CON
BASSORILIEVO /
WITH BAS-RELIEF
MOTIF**





**STILE CON BASSORILIEVO /
WITH BAS-RELIEF MOTIF STYLE**

**Serie Meridiana /
Meridiana Series**

model 581

**laccato opaco /
matt lacquered**

perla

Collection Leggera

Design Michele Marcon

**STILE CON BASSORILIEVO /
WITH BAS-RELIEF MOTIF STYLE**

**Serie Meridiana /
Meridiana Series**

model 580

laccato opaco /
matt lacquered

salvia

Collection Opera50

Apertura Silenzio /
Silenzio Opening

Design Michele Marcon









**STILE BASSORILIEVO /
BAS-RELIEF MOTIF STYLE**

**Serie Meridiana /
Meridiana Series**

model 580

laccato opaco /
matt lacquered
cashmere

Design Michele Marcon

DETTAGLI

Il minimalismo di questo bassorilievo unisce il design elementare all'essenza sensoriale, donata da ricercatezza di proporzione e bilanciamento.

DETAILS

The minimalism of this bas-relief combines elementary design with sensory essence, given by refinement of proportion and balance.

**STILE CON BASSORILIEVO /
WITH BAS-RELIEF MOTIF STYLE**

**Serie Meridiana /
Meridiana Series**

model 581

laccato opaco /
matt lacquered

perla

**Collection Scorrevoli Special
Alchemy**

Design Michele Marcon





**STILE CON BASSORILIEVO /
WITH BAS-RELIEF MOTIF STYLE**

**Serie Meridiana /
Meridiana Series**

model 581

*laccato opaco /
matt lacquered*

perla

Collection Leggera

Design Michele Marcon







**STILE BASSORILIEVO /
BAS-RELIEF MOTIF STYLE**

**Serie Meridiana /
Meridiana Series**

model 581

laccato opaco /
matt lacquered
canapa

Design Michele Marcon

DETTAGLI

Il bassorilievo dà prestigio all'anta spezzando l'ortogonalità attraverso un segno obliquo che parte dalla maniglia e arriva fino a terra. Una scelta decisa nel rispetto del minimalismo.

DETAILS

The bas-relief gives prestige to the door by breaking the orthogonality through an oblique sign that starts from the handle and reaches the ground. A bold choice in keeping with minimalism.

**STILE CON BASSORILIEVO /
WITH BAS-RELIEF MOTIF STYLE**

**Serie Meridiana /
Meridiana Series**

model 582

*laccato opaco /
matt lacquered*

canapa

**Collezione Vivace con stipite su misura e coprifilo telescopico /
Collection Vivace with custom-made jamb and telescopic casing**

Design Michele Marcon





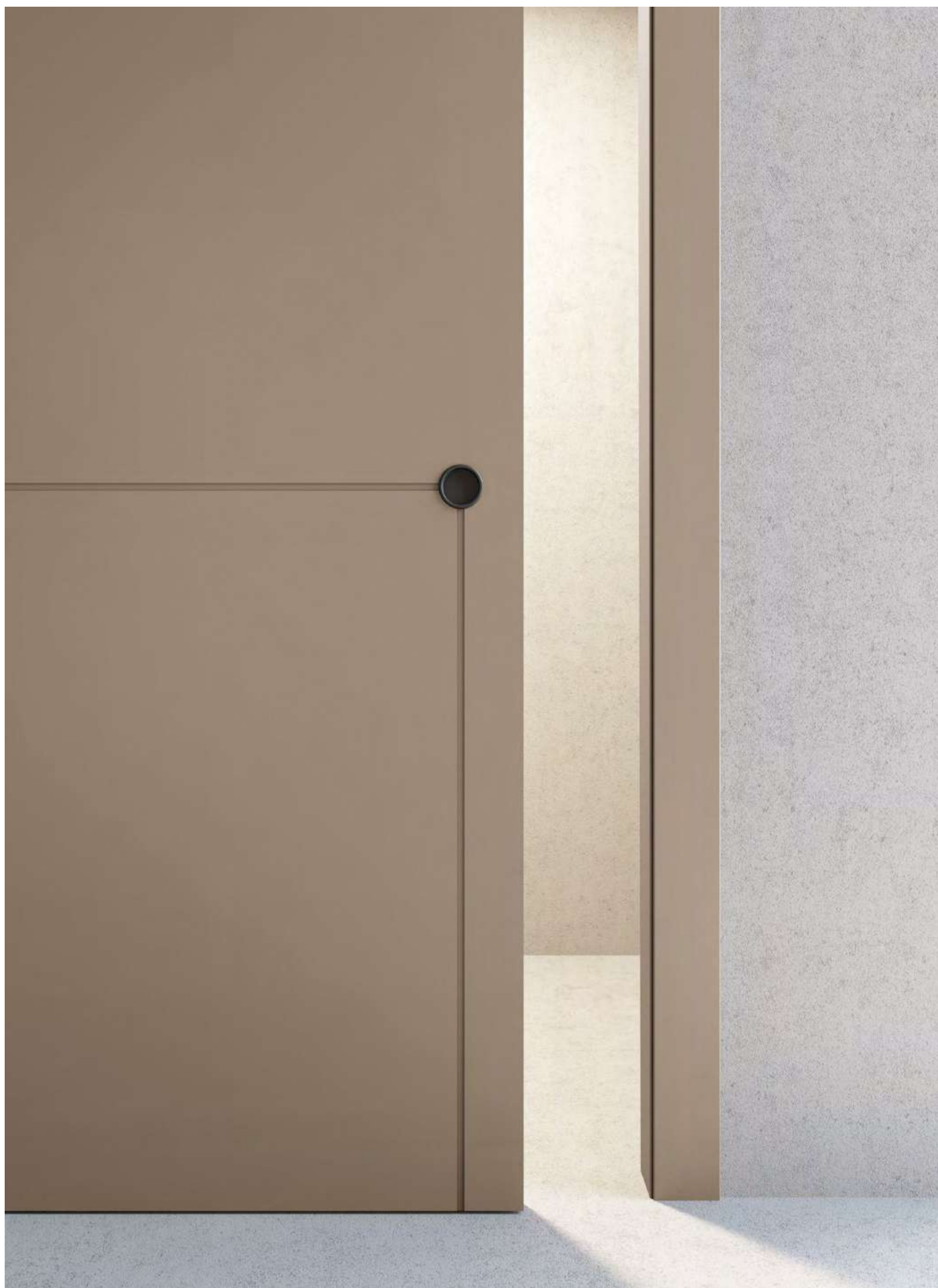



**STILE CON BASSORILIEVO /
WITH BAS-RELIEF MOTIF STYLE**

**Serie Meridiana /
Meridiana Series**

model 582

laccato opaco /
matt lacquered

basalto

Design Michele Marcon

DETTAGLI

Un modello pensato per chi apprezza la pulizia formale senza rinunciare ad un ambiente in cui la porta dà un tocco di design.

Le linee in bassorilievo partono dal fulcro della maniglia per percorrere ortogonalmente tutta la superficie dell'anta fino al bordo.

DETAILS

A model designed for those who appreciate formal cleanliness without compromising on the design of the room.

The bas-relief lines start at the fulcrum of the handle and run orthogonally across the entire surface of the door to the edge.

**STILE BASSORILIEVO /
BAS-RELIEF MOTIF STYLE**

**Serie Random /
Random Series**

model 295

frassino laccato spazzolato /
brushed lacquered ash wood

cadetto

tutt'altezza /
full height

**Collection Scorrevoli Special
Minimal Soft Pro**

Design Michele Marcon

MODELLO DEPOSITATO / REGISTERED PATTERN





STILE BASSORILIEVO / BAS-RELIEF MOTIF STYLE

model 287

frassino laccato spazzolato /
brushed lacquered ash wood

cadetto

tutt'altezza / *full height*

**Collection Scorrevoli Special
Alchemy**

Design Michele Marcon

MODELLO DEPOSITATO / REGISTERED PATTERN





**STILE BASSORILIEVO /
BAS-RELIEF MOTIF STYLE
model 283**

frassino laccato spazzolato /
brushed lacquered ash wood
tortora

Design Michele Marcon

MODELLO DEPOSITATO /
REGISTERED PATTERN



**STILE BASSORILIEVO /
BAS-RELIEF MOTIF STYLE
model 286**

laccato opaco /
matt lacquered
perla

Design Michele Marcon

MODELLO DEPOSITATO /
REGISTERED PATTERN

**STILE BASSORILIEVO /
BAS-RELIEF MOTIF STYLE**

model 285

laccato opaco /
matt lacquered

ghiaia

tutt'altezza / *full height*

Collection Leggera

Design Michele Marcon

MODELLO DEPOSITATO / REGISTERED PATTERN



**STILE BASSORILIEVO /
BAS-RELIEF MOTIF STYLE**

model 285

laccato opaco /
matt lacquered

ghiaia

tutt'altezza / *full height*

**Collection Scorrevoli Special
Alchemy**

Design Michele Marcon

MODELLO DEPOSITATO / REGISTERED PATTERN



**STILE BASSORILIEVO /
BAS-RELIEF MOTIF STYLE**
model 281

frassino laccato spazzolato /
brushed lacquered ash wood

perla

tutt'altezza / *full height*

Collection Opera50

Design Michele Marcon

MODELLO DEPOSITATO / REGISTERED PATTERN



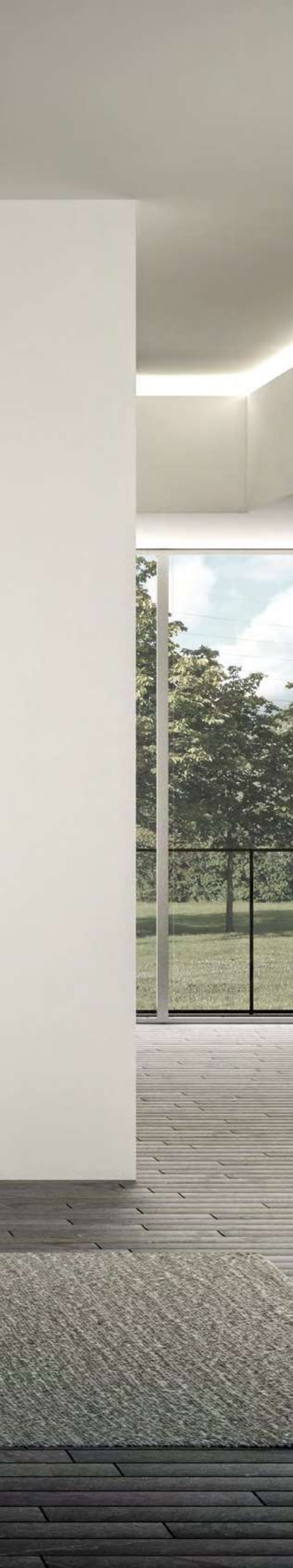

**STILE BASSORILIEVO /
BAS-RELIEF MOTIF STYLE
model 280**

frassino laccato spazzolato /
*brushed lacquered ash wood
corda*

Design Michele Marcon

MODELLO DEPOSITATO /
REGISTERED PATTERN



**STILE BASSORILIEVO /
BAS-RELIEF MOTIF STYLE
model 282**

laccato opaco /
*matt lacquered
sabbia*

Design Michele Marcon

MODELLO DEPOSITATO /
REGISTERED PATTERN



**STILE BASSORILIEVO /
BAS-RELIEF MOTIF STYLE**

model 277

*laccato opaco /
matt lacquered*

corda

Collection Unica



**STILE BASSORILIEVO /
BAS-RELIEF MOTIF STYLE**

model 274

*laccato opaco /
matt lacquered*

panna



**STILE BASSORILIEVO /
BAS-RELIEF MOTIF STYLE**

model 271

*laccato opaco /
matt lacquered*

tortora



**STILE BASSORILIEVO /
BAS-RELIEF MOTIF STYLE**
model 275
laccato opaco /
matt lacquered
bianco candido
Collection Unica



**STILE BASSORILIEVO /
BAS-RELIEF MOTIF STYLE**

model 272

laccato opaco /
matt lacquered

avorio



**STILE BASSORILIEVO /
BAS-RELIEF MOTIF STYLE**

model 278

laccato opaco /
matt lacquered

tortora

**STILE BASSORILIEVO /
BAS-RELIEF MOTIF STYLE**

model 270

*frassino laccato spazzolato /
brushed lacquered ash wood*

avorio

Collection Unica





**STILE BASSORILIEVO /
BAS-RELIEF MOTIF STYLE**

model 273

*laccato opaco /
matt lacquered*

sabbia



**STILE BASSORILIEVO /
BAS-RELIEF MOTIF STYLE**

model 276

*laccato opaco /
matt lacquered*

agata

**STILE BASSORILIEVO /
BAS-RELIEF MOTIF STYLE**

**Serie 10 mm /
10 mm Series**

model 569

laccato opaco /
matt lacquered
ghiaia

Design Michele Marcon

MODELLO DEPOSITATO /
REGISTERED PATTERN



**STILE BASSORILIEVO /
BAS-RELIEF MOTIF STYLE**

**Serie 10 mm /
10 mm Series**

model 571

laccato opaco /
matt lacquered
tortora

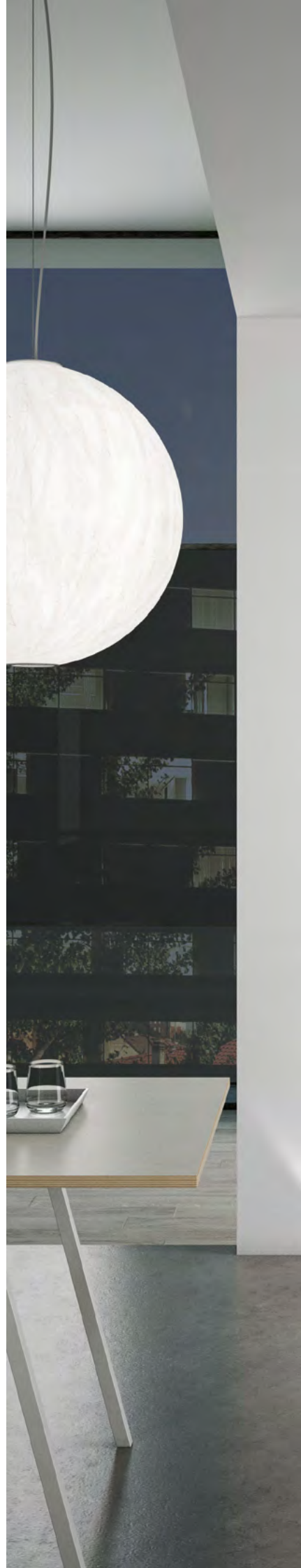



STILE BASSORILIEVO / BAS-RELIEF MOTIF STYLE

Serie 10 mm / 10 mm Series

model 568

laccato opaco / matt lacquered

cadetto

al soffitto / to ceiling

Collection Leggera





**STILE BASSORILIEVO /
BAS-RELIEF MOTIF STYLE**

**Serie 10 mm /
10 mm Series**

model 566

laccato opaco /
matt lacquered

agata

tutt'altezza /
full height

Collection Opera50

Design Michele Marcon

MODELLO DEPOSITATO / REGISTERED PATTERN



**STILE BASSORILIEVO /
BAS-RELIEF MOTIF STYLE**

**Serie 10 mm /
10 mm Series**

model 561

laccato opaco /
matt lacquered

ghiaia

Collection Opera50

Design Michele Marcon

MODELLO DEPOSITATO / REGISTERED PATTERN





**STILE BASSORILIEVO /
BAS-RELIEF MOTIF STYLE**

**Serie 10 mm /
10 mm Series
model 562**

laccato opaco /
matt lacquered
panna



**STILE BASSORILIEVO /
BAS-RELIEF MOTIF STYLE**

**Serie 10 mm /
10 mm Series
model 563**

laccato opaco /
matt lacquered
sabbia

**STILE BASSORILIEVO /
BAS-RELIEF MOTIF STYLE**

**Serie 10 mm ridotto /
10 mm reduced Series**

model 503

laccato opaco /
matt lacquered

panna



**STILE BASSORILIEVO /
BAS-RELIEF MOTIF STYLE**

**Serie 10 mm ridotto /
10 mm reduced Series**

model 511

laccato opaco /
matt lacquered

sabbia



Design Michele Marcon

MODELLO DEPOSITATO /
REGISTERED PATTERN





**STILE BASSORILIEVO /
BAS-RELIEF MOTIF STYLE**

**Serie 10 mm ridotto /
10 mm reduced Series**

model 502

**laccato opaco /
matt lacquered**

bianco Pivato

Collection Unica



**STILE BASSORILIEVO /
BAS-RELIEF MOTIF STYLE**

**Serie Random /
Random Series**

model 296

*laccato opaco /
matt lacquered*

agata

al soffitto / to ceiling

Collection Leggera

Design Michele Marcon

MODELLO DEPOSITATO / REGISTERED PATTERN

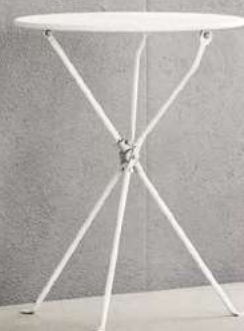

**STILE BASSORILIEVO /
BAS-RELIEF MOTIF STYLE**

**Serie Random /
Random Series**

model 296

*frassino laccato spazzolato /
brushed lacquered ash wood*

sabbia

tutt'altezza / full height

Collection Unica

Design Michele Marcon

MODELLO DEPOSITATO / REGISTERED PATTERN

GALLERY



Stile / Style

**CON
BASSORILIEVO
E INCISIONE /
*WITH BAS-RELIEF
AND ENGRAVED
MOTIF***



STILE BASSORILIEVO E INCISIONE /
BAS-RELIEF AND ENGRAVED MOTIF STYLE

model 601

laccato opaco /
matt lacquered

beige

al soffitto / to ceiling

Collection Leggera

Design Michele Marcon

MODELLO DEPOSITATO / REGISTERED PATTERN

GALLERY





STILE CON BASSORILIEVO E INCISIONE /
WITH BAS-RELIEF AND ENGRAVED MOTIF STYLE

Serie Meridiana /
Meridiana Series

model 610

laccato opaco /
matt lacquered

cashmere

Collection Scorrevoli Special
Light

Design Michele Marcon







**STILE CON BASSORILIEVO E
INCISIONE / WITH BAS-RELIEF
AND ENGRAVED MOTIF STYLE**

**Serie Meridiana /
Meridiana Series**

model 610

laccato opaco /
matt lacquered
ardesia

Design Michele Marcon

DETTAGLI

La porta diventa protagonista dell'ambiente. Linee a bassorilievo e incise vengono proiettate dalla maniglia verso le estremità dell'anta, come succede nelle meridiane quando lo stilo proietta la propria ombra sul quadro di riferimento.

DETAILS

The door becomes the main element of the room. Bas-relief and engraved lines are projected from the handle towards the ends of the door, as happens in sundials when the stylus casts its shadow on the dial.



**STILE BASSORILIEVO E INCISIONE /
BAS-RELIEF AND ENGRAVED MOTIF**

model 600

laccato opaco /
matt lacquered

bianco Pivato

Collection Unica

Design Michele Marcon

MODELLO DEPOSITATO / REGISTERED PATTERN



**STILE BASSORILIEVO E
INCISIONE /
BAS-RELIEF AND ENGRAVED
MOTIF STYLE**

model 602

laccato opaco /
matt lacquered
cadetto

Design Michele Marcon

MODELLO DEPOSITATO /
REGISTERED PATTERN



**STILE BASSORILIEVO E
INCISIONE /
BAS-RELIEF AND ENGRAVED
MOTIF STYLE**

model 603

laccato opaco /
matt lacquered
cadetto

Design Michele Marcon

MODELLO DEPOSITATO /
REGISTERED PATTERN

Stile / *Style*

PANTOGRAFATA /
PANTOGRAPHED

6 diversi segni per sei diversi linguaggi estetici:
features for six different aesthetic languages:

TOSCA

CARMEN

IRIS

MEDEA

TURANDOT

AIDA





MEDEA



TURANDOT



AIDA

Tosca

Viene realizzata attraverso una pantografatura addolcita nel bordo che conferisce alla porta uno stile **classico intramontabile**.

*It is made through a softened pantograph in the door edge which gives it a **timeless classic style**.*

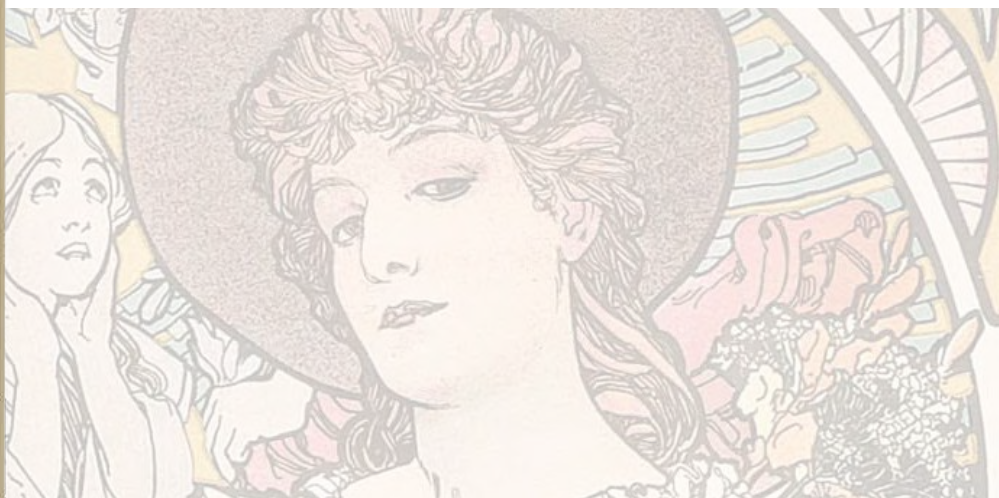

Carmen

Aggiunge a Tosca due segni verticali incisi sull'anta che ne arricchiscono il disegno per donarle uno stile dal **gusto rétro**.

*Compared to Tosca, Carmen also has two vertical lines engraved on the door, enriching the design and giving it a **retro style**.*



Iris

Con la sua pantografatura lineare e squadrata, è la più minimale tra tutte le lavorazioni: un gusto **classico rivisitato in chiave moderna**.

*With its linear and squared pantograph, it is the most minimal of all the manufactures: a **classic taste revisited in a modern key**.*

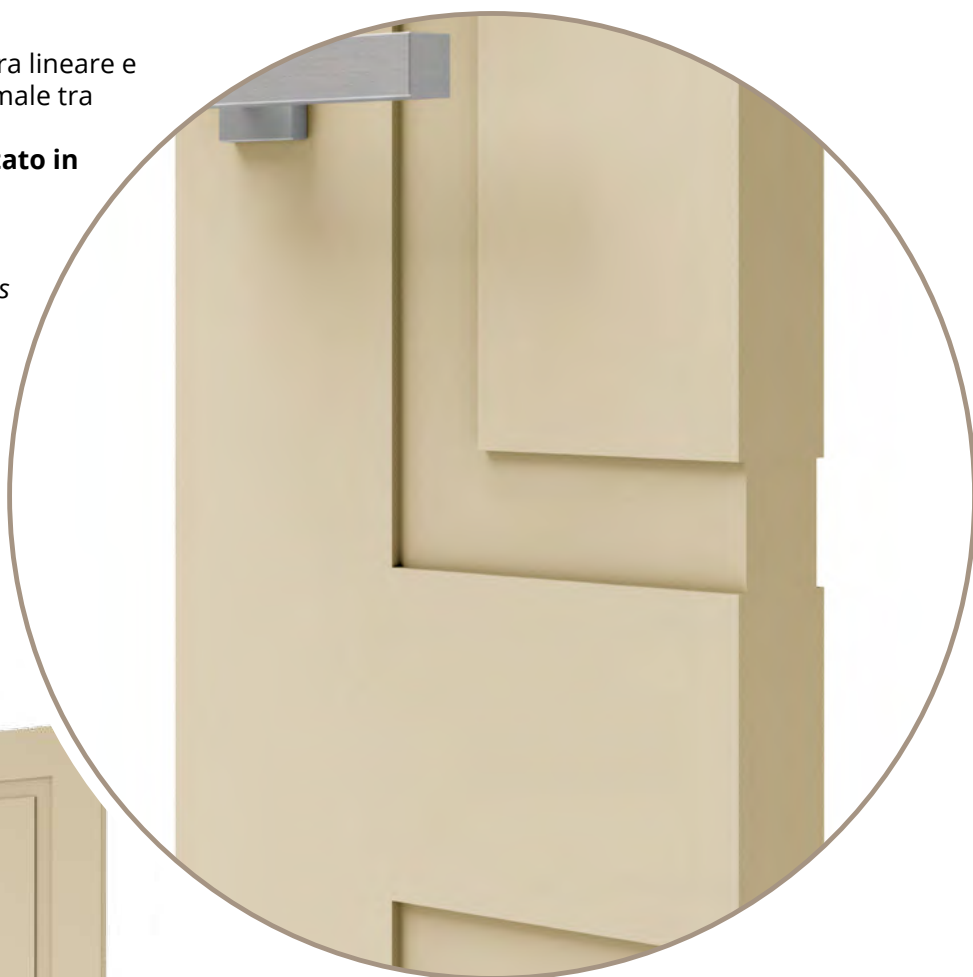

Medea

Aggiunge a Iris due segni verticali incisi sull'anta per proporre una soluzione che racchiuda nello stesso design **semplicità e classicismo**.

*Compared to Iris, Medea also has two vertical signs engraved on the door, to suggest a solution that combines **simplicity and classicism** in the same design.*



Turandot

Combina la pantografatura lineare e squadrata, tipica di Iris, con il segno dell'incisione per realizzare un **design di carattere.**

*It combines the linear, square pantograph, typical of Iris, with the sign of engraving to create a **design with personality.***

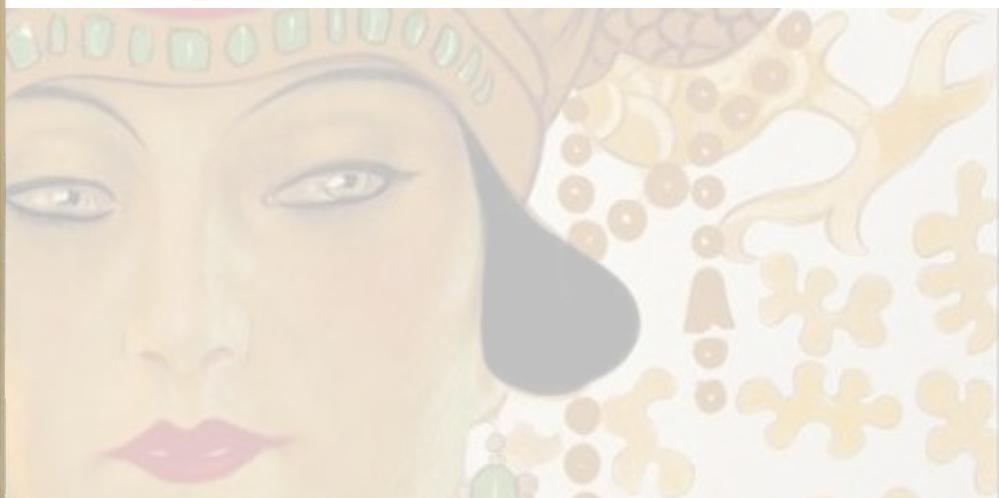

Aida

Ha una pantografatura il cui disegno si sviluppa su tre livelli: questo gioco di profondità crea un **design esclusivo**.

*Its pantograph is developed on three levels: this play of layers creates an **exclusive design**.*





**STILE PANTOGRAFATA /
PANTOGRAPHED STYLE**

model 190

*laccato opaco /
matt lacquered*

bianco Pivato

Collection Dinamica

*pantografatura Tosca /
pantographie Tosca*

*coprifilo classico /
classic casing*





**STILE PANTOGRAFATA /
PANTOGRAPHED STYLE**

model 191

laccato opaco /
matt lacquered

bianco candido

Collection Dinamica

pantografatura Carmen /
pantographie Carmen

coprifilo barocco /
baroque casing







**STILE PANTOGRAFATA /
PANTOGRAPHED STYLE**

model 193

laccato opaco /
matt lacquered

sabbia

pantografatura Iris /
pahntographe Iris

**STILE PANTOGRAFATA /
PANTOGRAPHED STYLE**

model 196

frassino laccato spazzolato /
brushed lacquered ash wood

corda

Collection Unica

pantografatura Iris /
pahntographe Iris

**STILE PANTOGRAFATA /
PANTOGRAPHED STYLE**

model 202

*laccato opaco /
matt lacquered*

panna

Collection Unica

*pantografatura Medea /
pahntographe Medea*









**STILE PANTOGRAFATA /
PANTOGRAPHED STYLE**

model 205

*laccato opaco /
matt lacquered*

perla

tutt'altezza / full height

Collection Unica

*pantografatura Turandot /
pahntographe Turandot*

**STILE PANTOGRAFATA /
PANTOGRAPHED STYLE**

model 206

laccato opaco /
matt lacquered
cadetto

Collection Unica

pantografatura Aida /
pahntographe Aida





Stile / Style

MODULAR / *MODULAR*



**STILE MODULAR /
MODULAR STYLE**

model 321

rovere bianco spazzolato /
brushed white oak

tutt'altezza /
full height

Collection Dinamica







**STILE MODULAR /
MODULAR STYLE**

model 332

rovere bianco spazzolato /
brushed white oak

apertura Silenzio /
Silenzio opening

Collection Unica

**STILE MODULAR /
MODULAR STYLE**

model 330

yellow pine laccato spazzolato /
brushed lacquered yellow pine

tortora

al soffitto / *to ceiling*

Collection Dinamica



**STILE MODULAR /
MODULAR STYLE**

model 331

*yellow pine laccato spazzolato /
brushed lacquered yellow pine*

tortora

al soffitto / to ceiling

Collection Dinamica

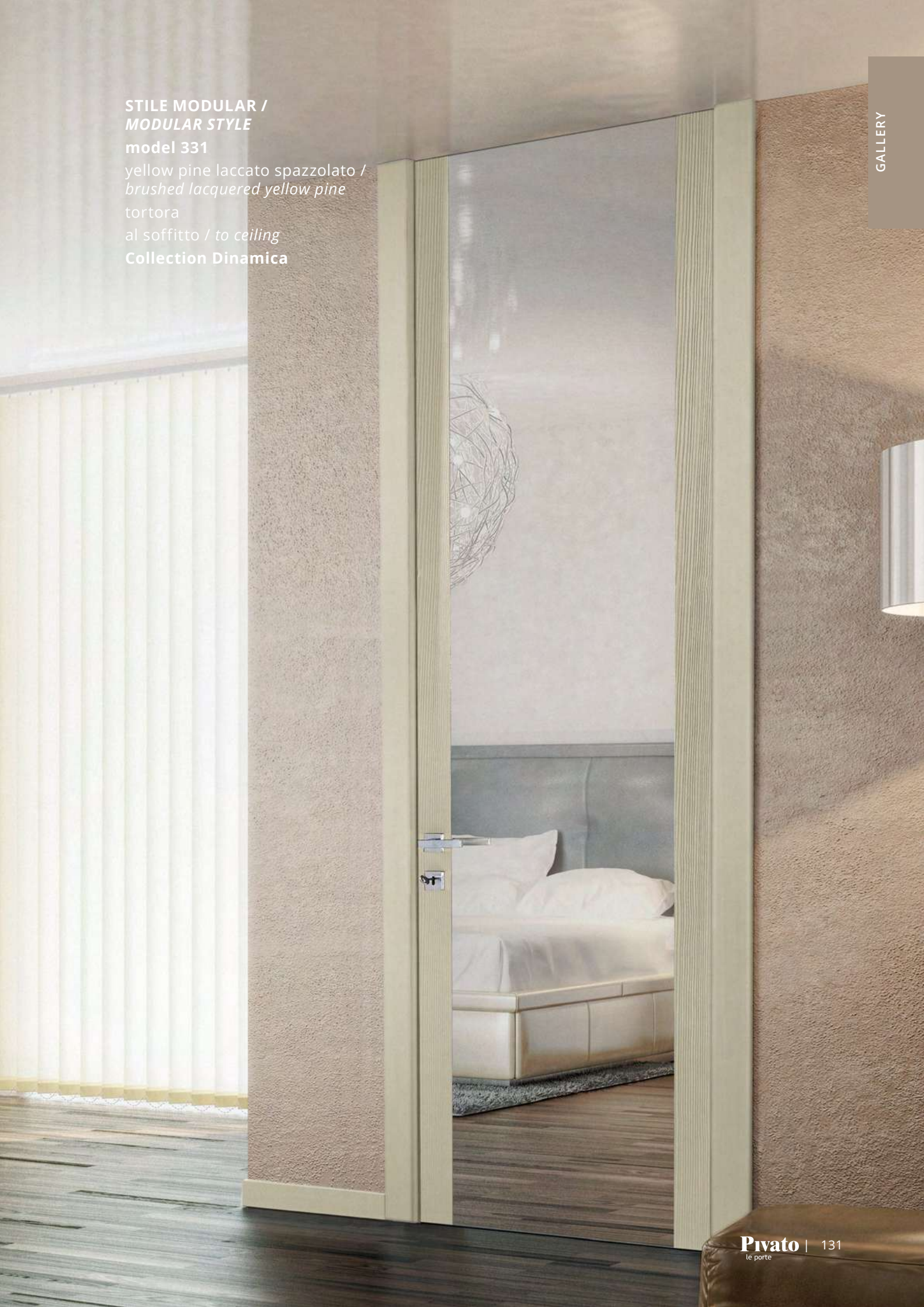

Stile / Style

LISTELLARE A VETRO / *BLOCKBOARD* *WITH GLASS*

**STILE LISTELLARE A VETRO /
*BLOCKBOARD WITH GLASS***

model 3200

frassino laccato spazzolato /
brushed lacquered ash wood

sabbia

vetro Ventiquattro

base trasparente /
transparent base

decoro laccato sabbia /
lacquered sabbia motif

Collection Unica





**STILE LISTELLARE A VETRO /
BLOCKBOARD WITH GLASS STYLE**

model 3200

frassino laccato spazzolato /
brushed lacquered ash wood

sabbia

vetro Ventiquattro

base trasparente /
transparent base

deco laccato sabbia /
lacquered sabbia motif



**STILE LISTELLARE A VETRO /
BLOCKBOARD WITH GLASS STYLE**

model 3200

laccato opaco /
matt lacquered

bianco Pivato

vetro Venticinque

base sabbata /
sandblasted base

deco trasparente /
transparent motif



**STILE LISTELLARE A VETRO /
BLOCKBOARD WITH GLASS STYLE**

model 3200

frassino laccato spazzolato /
brushed lacquered ash wood

tortora

vetro Ventisei

base laccata tortora /
tortora lacquered base

deco trasparente /
transparent motif



STILE LISTELLARE A
VETRO / BLOCKBOARD
WITH GLASS STYLE

model 3400

laccato opaco /
matt lacquered

tortora

Collection Scorrevoli Special
Linear 20



**STILE LISTELLARE A VETRO /
BLOCKBOARD WITH GLASS STYLE
model 3421**

olmo brandy spazzolato /
brushed brandy elm



**STILE LISTELLARE A VETRO /
BLOCKBOARD WITH GLASS STYLE
model 3412**

laccato opaco /
matt lacquered
avorio



**STILE LISTELLARE A VETRO /
BLOCKBOARD WITH GLASS**
model 3400

rovere grigio spazzolato /
brushed gray oak
rototraslante /
pivot sliding door
vetro Mosaico
vetro sabbato /
sandblasted glass
Collection Dinamica



**STILE LISTELLARE A VETRO /
BLOCKBOARD WITH GLASS**
model 3300

rovere grigio spazzolato /
brushed gray oak



**STILE LISTELLARE A VETRO /
BLOCKBOARD WITH GLASS**
model 3301

laccato opaco /
matt lacquered
tortora

Stile / Style

**LISTELLARE
CIECA /
BLOCKBOARD
*SOLID***



STILE LISTELLARE CIECA /
BLOCKBOARD SOLID STYLE

model 3621

olmo brandy spazzolato /
brushed brandy elm

Collezione Vivace con stipite su misura e coprifilo telescopico /
Collection Vivace with custom-made jamb and telescopic casing

GALLERY





**STILE LISTELLARE CIECA /
BLOCKBOARD SOLID STYLE
model 3612**

rovere bianco spazzolato /
brushed white oak



**STILE LISTELLARE CIECA /
BLOCKBOARD SOLID STYLE
model 3600**

laccato opaco /
matt lacquered
ghiaia



**STILE LISTELLARE CIECA /
BLOCKBOARD SOLID STYLE
model 3611**

laccato opaco /
matt lacquered
basalto



**STILE LISTELLARE CIECA /
BLOCKBOARD SOLID STYLE
model 3621**

frassino spazzolato /
brushed ash wood
canapa



Maniglie scavate

Carved handles

La maniglia è un elemento caratterizzante della porta: ne arricchisce la personalità, ne richiama il contatto, ne definisce lo stile.

Le maniglie scavate nell'anta sono prerogativa della Linea Legno di Pivato. Sono come delle sculture nel legno, si ispirano alla storia dell'arte e ai suoi più famosi interpreti.

The handle is a characterising element of the door: it enriches its personality, recalls its contact, defines its style.

The handles carved into the door are a prerogative of Pivato's Linea Legno. They are like sculptures in wood, inspired by the history of art and its most famous interpreters.



BOTERO

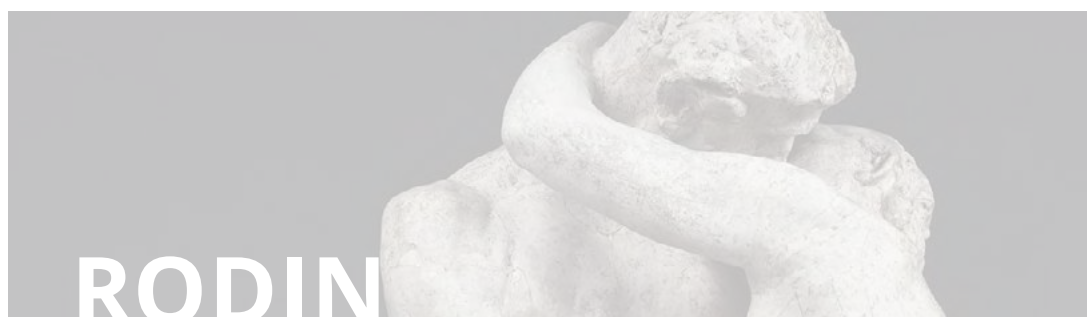

RODIN



BRUNELLESCHI



MICHELANGELO



CORRADINI

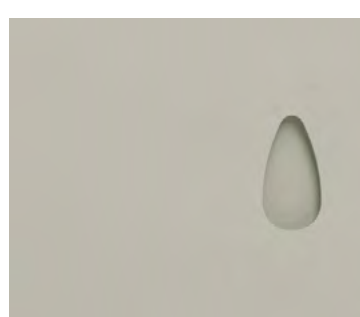

MANIGLIA / HANDLE

Botero

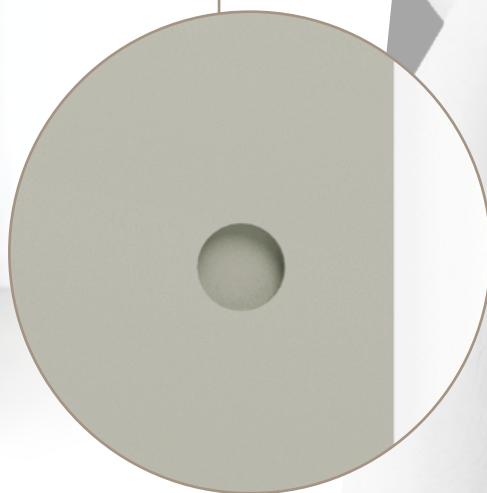

Botero è la maniglia scavata completamente in tondo: è il cerchio pieno e abbondante della vita.

(altro a p. 98)

Botero is the handle carved completely in the round: it is the rich, full circle of life.

(more at page 98)

MANIGLIA / HANDLE

Rodin

GALLERY

MANIGLIE SCAVATE

GUIDA

COLLEZIONI

PLUS

COMPLEMENTI

L'AZIENDA



Rodin è la maniglia scavata secondo proporzioni quadrate: è la semplice complessità della tecnica.

(altro a p. 62)

Rodin is the handle carved to square proportions: it is the simple complexity of technique.

(more at page 62)

MANIGLIA / HANDLE

Brunelleschi

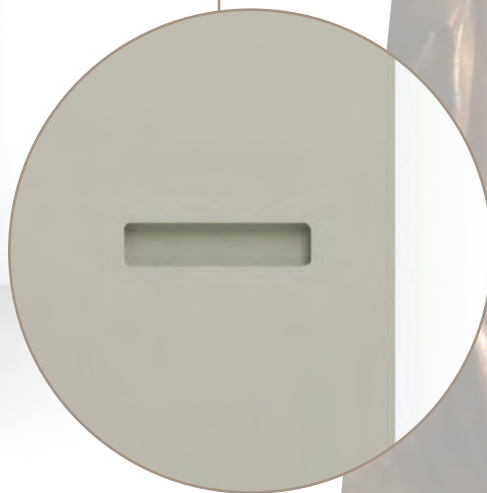

La maniglia Brunelleschi rappresenta la sintesi estetica della maniglia classica, ma trasposta all'interno dell'anta.

The Brunelleschi handle represents the aesthetic synthesis of the classic handle, but transposed inside the door.



MANIGLIA / HANDLE

Michelangelo

GALLERY

MANIGLIE SCAVATE

GUIDA

COLLEZIONI

PLUS

COMPLEMENTI

L'AZIENDA



La maniglia Michelangelo si distingue per un segno minimale scavato con rigorosa precisione.

The Michelangelo handle is notable for its minimalist design carved with rigorous precision.

MANIGLIA / HANDLE

Corradini



Con le sue forme tonde, la maniglia Corradini esalta la morbidezza del gesto con cui si apre l'anta.

With its round shape, the Corradini handle enhances the smoothness of the door opening gesture.

MANIGLIA / HANDLE

Donatello

GALLERY

MANIGLIE SCAVATE

GUIDA

COLLEZIONI

PLUS

COMPLEMENTI

L'AZIENDA



Donatello scava un solco verticale nell'anta, in modo da poter avvolgere la porta con la punta delle dita.

Donatello carves a vertical groove in the door so that you can wrap your fingertips around it.

MANIGLIA / HANDLE

Canova

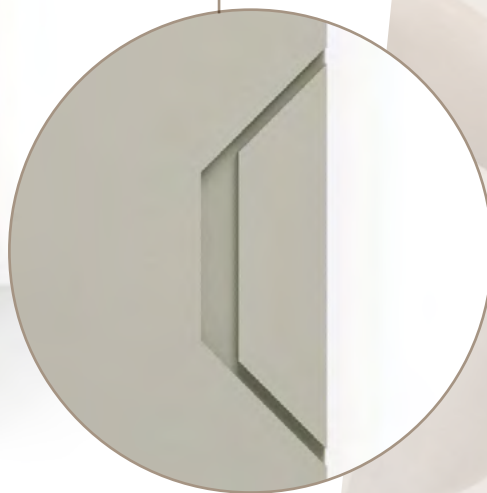
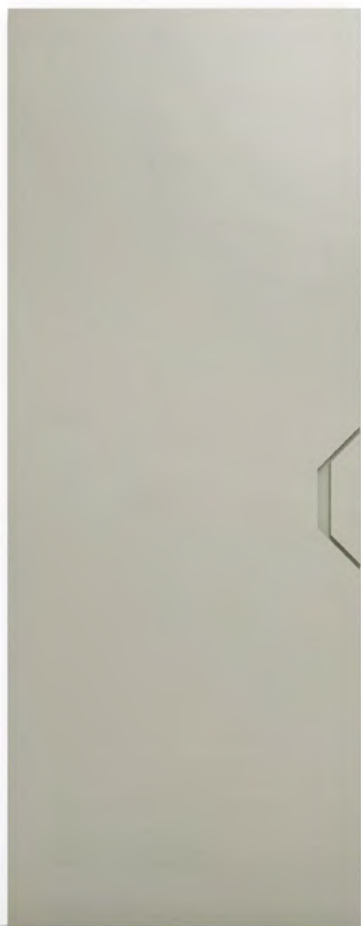

La maniglia Canova si slancia fino al limite dell'anta con vivacità: il segno a bassorilievo diventa protagonista dell'anta.

The Canova handle reaches up to the edge of the door with liveliness: the bas-relief sign becomes the protagonist of the door.

MANIGLIA / HANDLE

Cellini

GALLERY

MANIGLIE SCAVATE

GUIDA

COLLEZIONI

PLUS

COMPLEMENTI

L'AZIENDA



La maniglia Cellini estende il proprio segno scavato fino al limite dell'anta in modo perpendicolare, per una sensazione di netta stabilità nella presa.

The Cellini handle extends its carved shape perpendicularly to the door's edge, giving it a firm grip.

MANIGLIA / HANDLE

Bernini

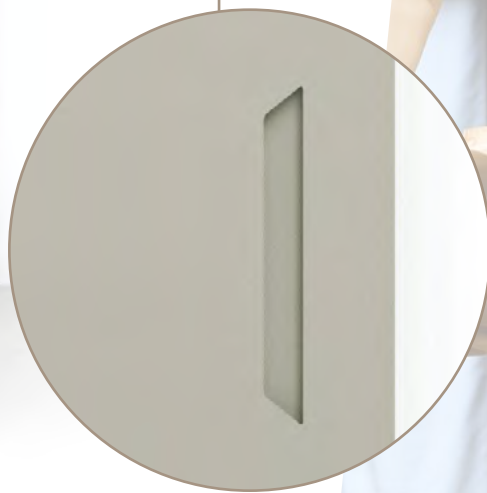

La maniglia Bernini crea luci e ombre grazie alla sua geometria originale.

The carved handle Bernini creates light and shade thanks to its original geometry. Maior is the larger version.



MANIGLIA / HANDLE

Boccioni

GALLERY

MANIGLIE SCAVATE

GUIDA

COLLEZIONI

PLUS

COMPLEMENTI

L'AZIENDA

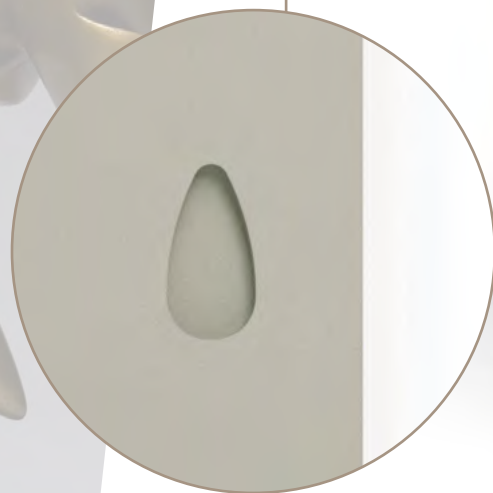

Questa maniglia scavata rappresenta più di tutte il dinamismo: goccia che cade o fiamma che cresce, Boccioni si apre all'interpretazione.

This carved handle represents dynamism more than anything else: drop falling or flame growing, Boccioni is open to interpretation.

Guida alla scelta

Choice guide

STILI

MODELLI

FINITURE E COLORI

APERTURE

COLLEZIONI

5 PASSI PER SCEGLIERE LA TUA PORTA 5 STEP TO CHOOSE YOUR DOOR

Con simpatia e grande senso pratico, questi due personaggi ispirati a Geppetto e Pinocchio ti racconteranno la "Guida alla scelta" in modo semplice e intuitivo.

Questa guida illustrata fa parte dell'Inserito Illustrato che puoi sfogliare a fine catalogo, creato dalla matita dell'illustratrice M.ELA (Michela Zalunardo) in collaborazione con Pivato. Sfoglia l'inserito illustrato completo a fine catalogo.

With sympathy and great practical sense, these two characters inspired by Geppetto and Pinocchio will tell you about the "Choice guide" in a simple and intuitive way.

This illustrated guide is part of the Illustrated Insert that you can read at the end of the catalogue, created by the talented illustrator M.ELA (Michela Zalunardo) in collaboration with Pivato. See the complete Illustrated Insert at the end of the catalogue.

1 STILE

COME VUOI CHE SIA FATTA LA TUA ANTA?

A seconda delle lavorazioni dell'anta ci sono diversi STILI.

Questi sono alcuni esempi. Più avanti vedremo tutti gli stili nel dettaglio.

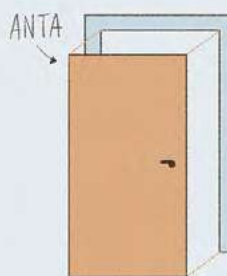

2 MODELLO

CHE VARIANTE VUOI?

Ogni stile offre diverse varianti, i MODELLI.

Ogni modello è denominato da un codice numerico!

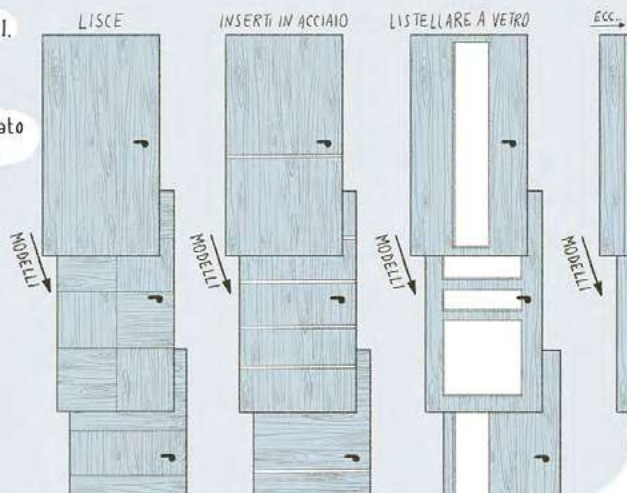

3 FINITURE E COLORI

CHE FINITURA E COLORE VUOI?



Un'ampia scelta per tutti i gusti!

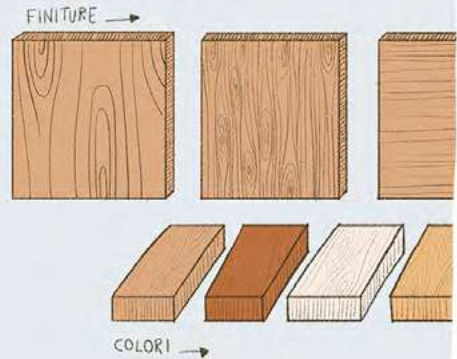

4 APERTURA

COME VUOI CHE SI APRA?



Scegli l'apertura più adatta alle tue esigenze!

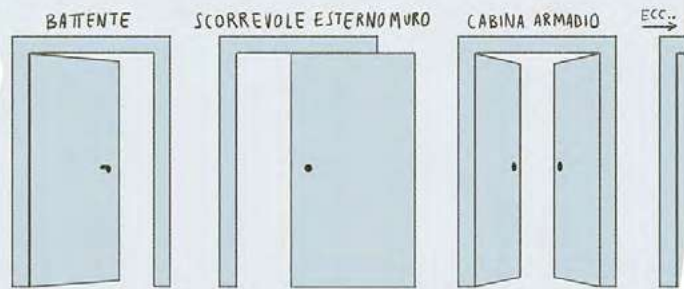

5 COLLEZIONE

COME VUOI CHE SIA FATTA LA "CORNICE" DELLA TUA PORTA?



A seconda di come è fatta la "cornice" abbiamo diverse COLLEZIONI.



In seguito vedremo tutte le collezioni!

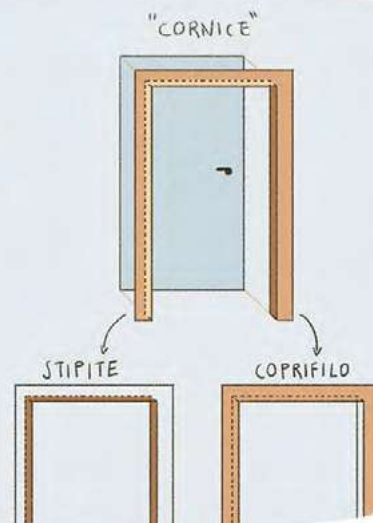

Lo stile / *The style*



LISCIA
SMOOTH

Semplice, moderna
e con una pulizia formale
sempre attuale.

*Simple, modern and
timeless clean lines.*

(da p. 6 a 21)



CON INSERTI IN ACCIAIO
WITH STEEL INSERTS

Design essenziale,
impreziosito da leggere
linee in acciaio.

*Essential design,
enhanced by
light steel lines.*

(da p. 22 a 25)



INCISA
ENGRAVED

Con l'Incisione anche i
decori più semplici e lineari
assumono un valore e una
preziosità che valorizza que-
sta lavorazione ebanistica.

*With Engraving even the sim-
plest and most linear deco-
ration becomes valuable and
precious, thus enhancing fine
woodworking.*

(da p. 26 a 55)

Scegli tra la serie di porte quella che più si addice al tuo stile.

Choose from the series of doors the one that suits your style.



CON BASSORILIEVO WITH BAS-RELIEF MOTIF

Il Bassorilievo è una soluzione scultorea che affonda le proprie radici nell'antichità e che esalta l'espressione artistica dei segni.

Bas-relief is a sculpture solution rooted in antiquity and enhances the artistic expression of elements.

(da p. 56 a 95)



CON BASSORILIEVO E INCISIONE WITH BAS-RELIEF AND ENGRAVED MOTIF

Quando queste due tecniche vengono contestualmente applicate, si ottiene una resa estetica di grande efficacia, con una profondità ed una tridimensionalità dei decori unica ed affascinante.

When these two techniques are simultaneously applied, the result is a particularly effective aesthetic yield featuring deep and three-dimensional decorations of unique and fascinating quality.

(da p. 96 a 103)

GALLERY

MANIGLIE SCAVATE

GUIDA
stile

COLLEZIONI

PLUS

COMPLEMENTI

L'AZIENDA

Lo stile / *The style*



PANTOGRAFATA
PANTOGRAPHED

Esalta le forme geometriche e rigorose suggerendo soluzioni che interrompono la planarità delle superfici con motivi decorativi di straordinaria semplicità.

It enhances geometric and rigorous shapes by suggesting solutions that interrupt the flatness of surfaces with decorative motifs of extraordinary simplicity.

(da p. 104 a 125)



MODULAR
MODULAR

Forme geometriche, ma non banali, per un design dinamico.

Uncommon geometric shapes for a dynamic design.

(da p. 126 a p. 131)

Scegli tra la serie di porte quella che più si addice al tuo stile.

Choose from the series of doors the one that suits your style.



LISTELLARE A VETRO
BLOCKBOARD WITH GLASS

Il vetro per creare la giusta atmosfera con ambienti più luminosi.

Glass to create the right ambience with brighter settings.

(da p. 132 a p. 139)



LISTELLARE CIECA
BLOCKBOARD SOLID

Uno stile senza età per un ambiente elegante e di classe.

An ageless style for an elegant and classy setting.

(da p. 140 a p. 143)

GALLERY

MANIGLIE SCAVATE

GUIDA
stile

COLLEZIONI

PLUS

COMPLEMENTI

L'AZIENDA

Il modello *The model*

Ogni stile può essere personalizzato grazie alla varietà dei modelli proposti in base al proprio gusto.

The range of models offered allows personalizing every style based upon each customer's discrete taste.

LISCIA SMOOTH

127



107



(p. 8-9)

Design by Michele Marcon

101



(p. 10)

128



(p. 12)

114

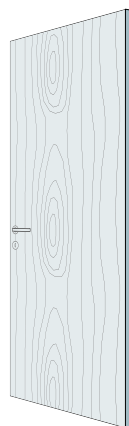

(p. 14-15)

102



129



(p. 12-13)

115



(p. 16-17)

103

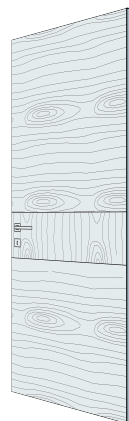

(p. 11)

122

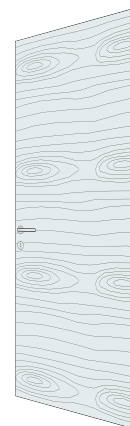

(p. 19-21)

105



(p. 8)

Design by Michele Marcon

124

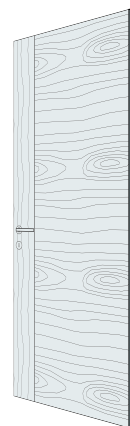

(p. 21)

106



(p. 7)

Design by Michele Marcon

**INCISA
ENGRAVED**

**CON INSERTI IN ACCIAIO
WITH STEEL INSERTS**

163

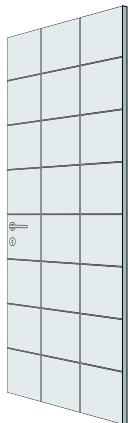

147

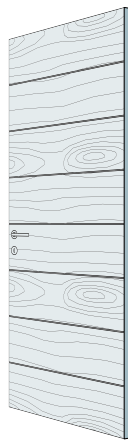

Registered pattern

(p. 52)

140

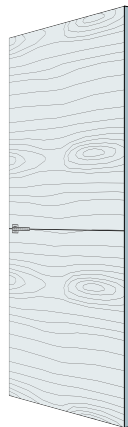

(p. 54)

130

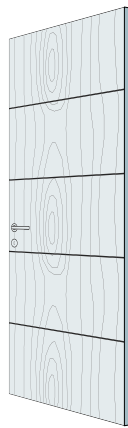

164



157



(p. 50)

141



(p. 55)

133



(p. 24)

165



158

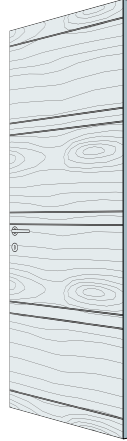

(p. 54)

142

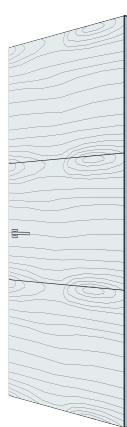

134

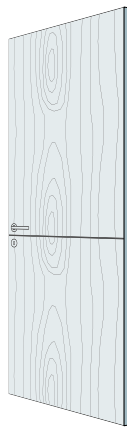

173

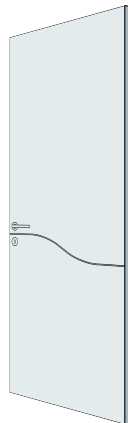

159

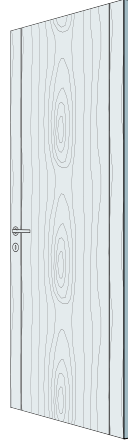

(p. 53)

143



(p. 23)

135

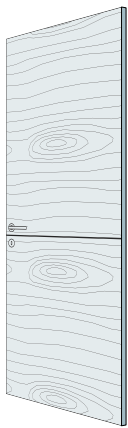

174

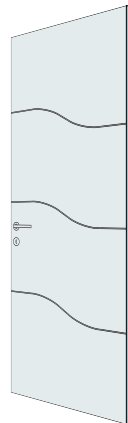

160

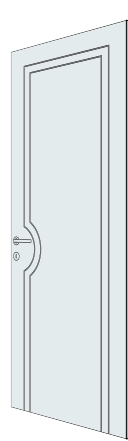

(p. 53)

144

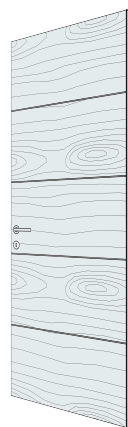

L'AZIENDA

COMPLEMENTI

PLUS

COLLEZIONI

GUIDA
modello

MANIGLIE SCAVATE

GALLERY

**INCISA
ENGRAVED**

440 / Serie Orbita (p. 34-37)



409 (p. 42, 45)

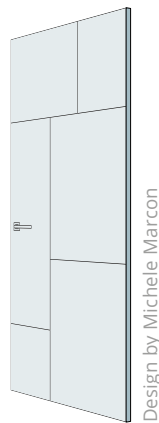

404 (p. 49)

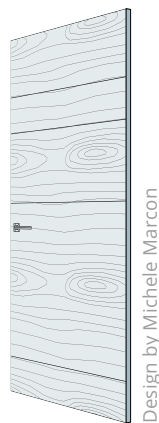

175

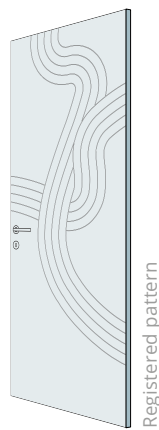

441 / Serie Orbita (p. 38-41)



410 (p. 44)

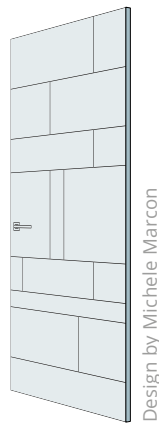

405 (p. 46)

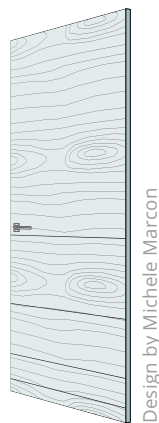

176

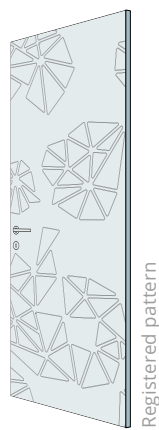

442 / Serie Orbita (p. 27-29)



411

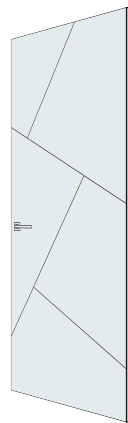

406 (p. 47)

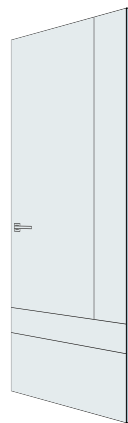

401

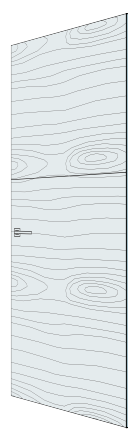

443 / Serie Orbita (p. 30-33)



412

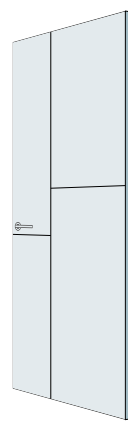

407 (p. 47)



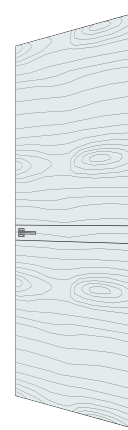

402

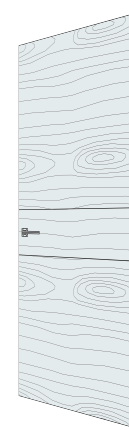

403

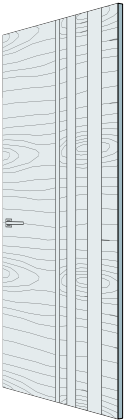

**CON BASSORILIEVO
WITH BAS-RELIEF MOTIF**

285	(p. 74-75)		280	(p. 77)		274	(p. 79)		261		
		Design by Michele Marcon / Registered pattern			Design by Michele Marcon / Registered pattern					Registered pattern	
286	(p. 73)		281	(p. 76)		275	(p. 80)		270	(p. 82)	
		Design by Michele Marcon / Registered pattern			Design by Michele Marcon / Registered pattern						
287	(p. 72)		282	(p. 77)		276	(p. 83)		271	(p. 79)	
		Design by Michele Marcon / Registered pattern			Design by Michele Marcon / Registered pattern						
295 / Serie Random	(p. 71)		283	(p. 73)		277	(p. 78)		272	(p. 81)	
		Design by Michele Marcon / Registered pattern			Design by Michele Marcon / Registered pattern						
296 / Serie Random	(p. 92-95)		284			278	(p. 81)		273	(p. 83)	
		Design by Michele Marcon / Registered pattern			Design by Michele Marcon / Registered pattern						

**CON BASSORILIEVO
WITH BAS-RELIEF MOTIF**

500 / Serie 10 mm ridotto

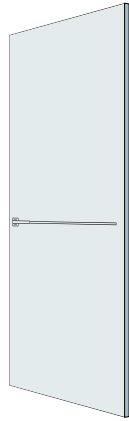

567 / Serie 10 mm



Design by Michele Marcon / Registered pattern

562 / Serie 10 mm



(p. 89)

550 / Serie 10 mm

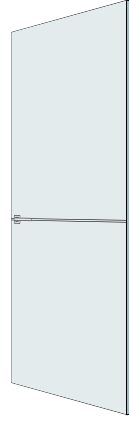

502 / Serie 10 mm ridotto (p. 91)

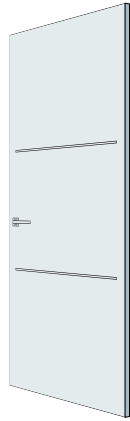

568 / Serie 10 mm

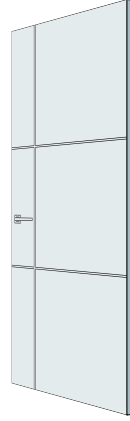

(p. 85)

563 / Serie 10 mm



(p. 89)

552 / Serie 10 mm



503 / Serie 10 mm ridotto (p. 90)

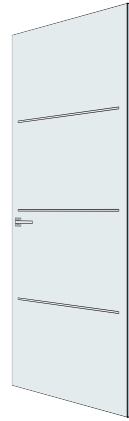

569 / Serie 10 mm

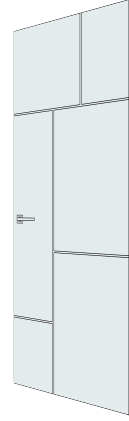

(p. 84)

564 / Serie 10 mm

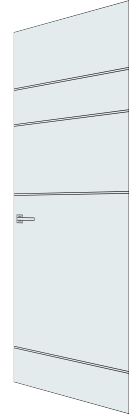

Design by Michele Marcon / Registered pattern

553 / Serie 10 mm



504 / Serie 10 mm ridotto



570 / Serie 10 mm



Design by Michele Marcon / Registered pattern

565 / Serie 10 mm



Design by Michele Marcon / Registered pattern

554 / Serie 10 mm

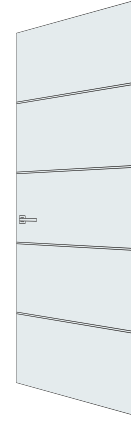

511 / Serie 10 mm ridotto (p. 90)

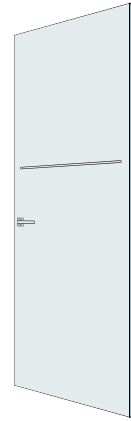

571 / Serie 10 mm

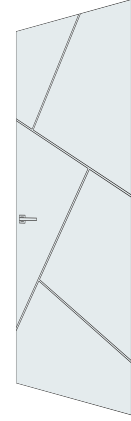

(p. 84)

566 / Serie 10 mm



(p. 86-87)

561 / Serie 10 mm



(p. 88)

Design by Michele Marcon / Registered pattern

Design by Michele Marcon / Registered pattern

Design by Michele Marcon / Registered pattern

**PANTOGRAFATA
PANTOGRAPHED**

195



196



202

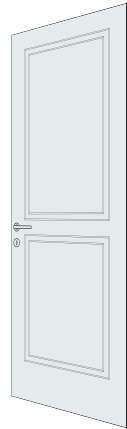

205

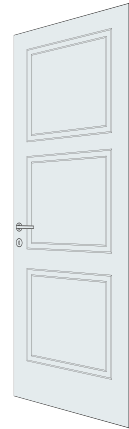

206



189



190

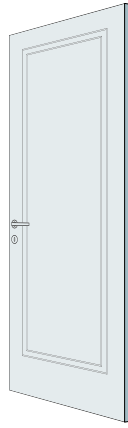

191



192



193



**CON BASSORILIEVO
E INCISIONE / WITH BAS-RELIEF
AND ENGRAVED MOTIF**

600 (p. 102)

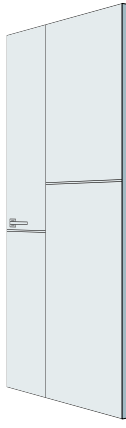

Design by Michele Marcon / Registered pattern

601 (p. 97)

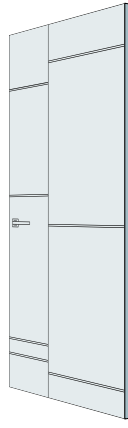

Design by Michele Marcon / Registered pattern

602 (p. 103)

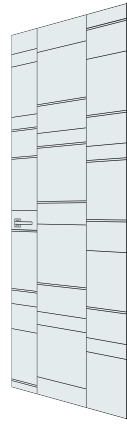

Design by Michele Marcon / Registered pattern

603 (p. 103)

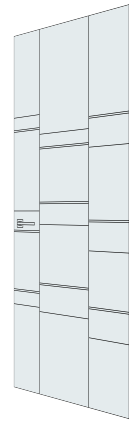

Design by Michele Marcon / Registered pattern

610 / Serie Meridiana (p. 98-101)



**CON BASSORILIEVO
WITH BAS-RELIEF MOTIF**

580 / Serie Meridiana (p. 59-61)



581 / Serie Meridiana (p. 62-65)



582 / Serie Meridiana (p. 66-69)



PANTOGRAFATA
PANTOGRAPHED



MODULAR
MODULAR



LISTELLARE CIECA
BLOCKBOARD SOLID

LISTELLARE A VETRO
BLOCKBOARD WITH GLASS

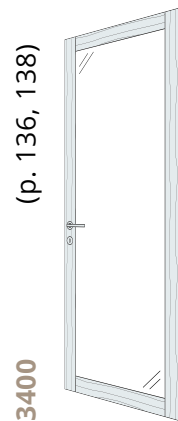
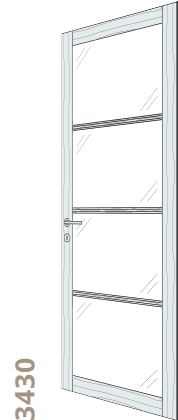
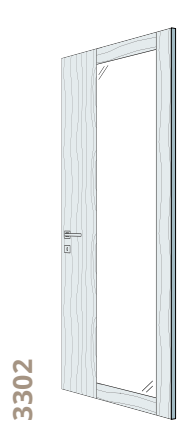
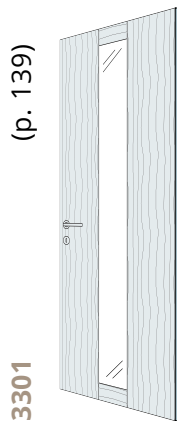
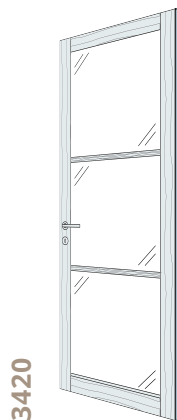
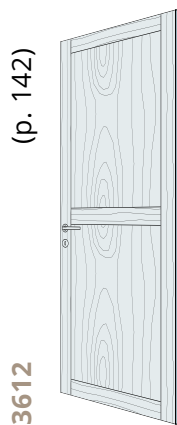
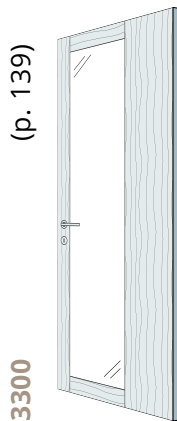
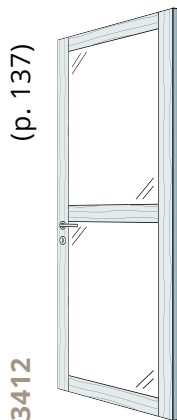
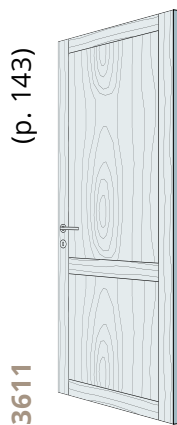
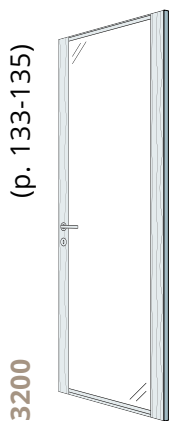
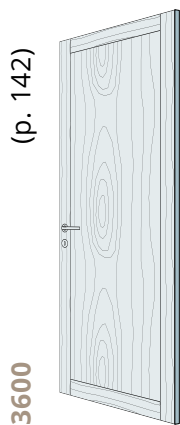

L'AZIENDA

COMPLEMENTI

PLUS

COLLEZIONI

GUIDA
modello

MANIGLIE SCAVATE

GALLERY



Serie Orbita



IL CONCEPT

La progettazione di una porta Pivato si concentra sui dettagli che nascono per essere in armonia con il design dell'ambiente.

Le porte diventano esse stesse **oggetti di design e un valore aggiunto per lo spazio che arredano.**

In collaborazione con il designer Michele Marcon abbiamo creato il design di quattro nuovi modelli – chiamati Serie Orbita: il punto di vista è decentrato, si concentra su **nuovi segni che ruotano attorno alla maniglia, il punto focale in cui veniamo in contatto con la porta.**

THE CONCEPT

The design of a Pivato door focuses on the details that are created to be in harmony with the design of the room.

*Our doors are themselves **design objects and an added value to the space they furnish.***

*In collaboration with designer Michele Marcon, we created the design of four new models – named Orbita Series: the point of view is decentred, focusing on **new signs that revolve around the handle, the point where we come into contact with the door.***



Serie Meridiana



IL CONCEPT

La porta Pivato come elemento d'arredo in armonia con l'ambiente circostante è il "fil rouge" da cui nasce questa Serie.

La perfetta funzionalità del prodotto sposa la ricercatezza estetica e l'armonia della forma.

Nascono quattro nuovi modelli detti Serie Meridiana realizzati attraverso le tecniche del bassorilievo e dell'incisione.

La maniglia infissa rispetto al piano dell'anta proietta metaforicamente la propria ombra attraverso linee a bassorilievo e incise che valorizzano in maniera semplice ed elegante il design dell'anta.

THE CONCEPT

The Pivato door is a decorative element in harmony with its surroundings. It is the "fil rouge" from which this Series was born.

The perfect functionality of the product meets aesthetic refinement and harmony of form.

*The result is four new models called Meridiana series, created using engraving and bas-relief technics. **The handle set into the door surface metaphorically projects its shadow by bas-relief and engraved lines** that enhance the design of the door in a simple and elegant way.*

Serie Orbita / *Orbita Series*

Design by
Michele Marcon

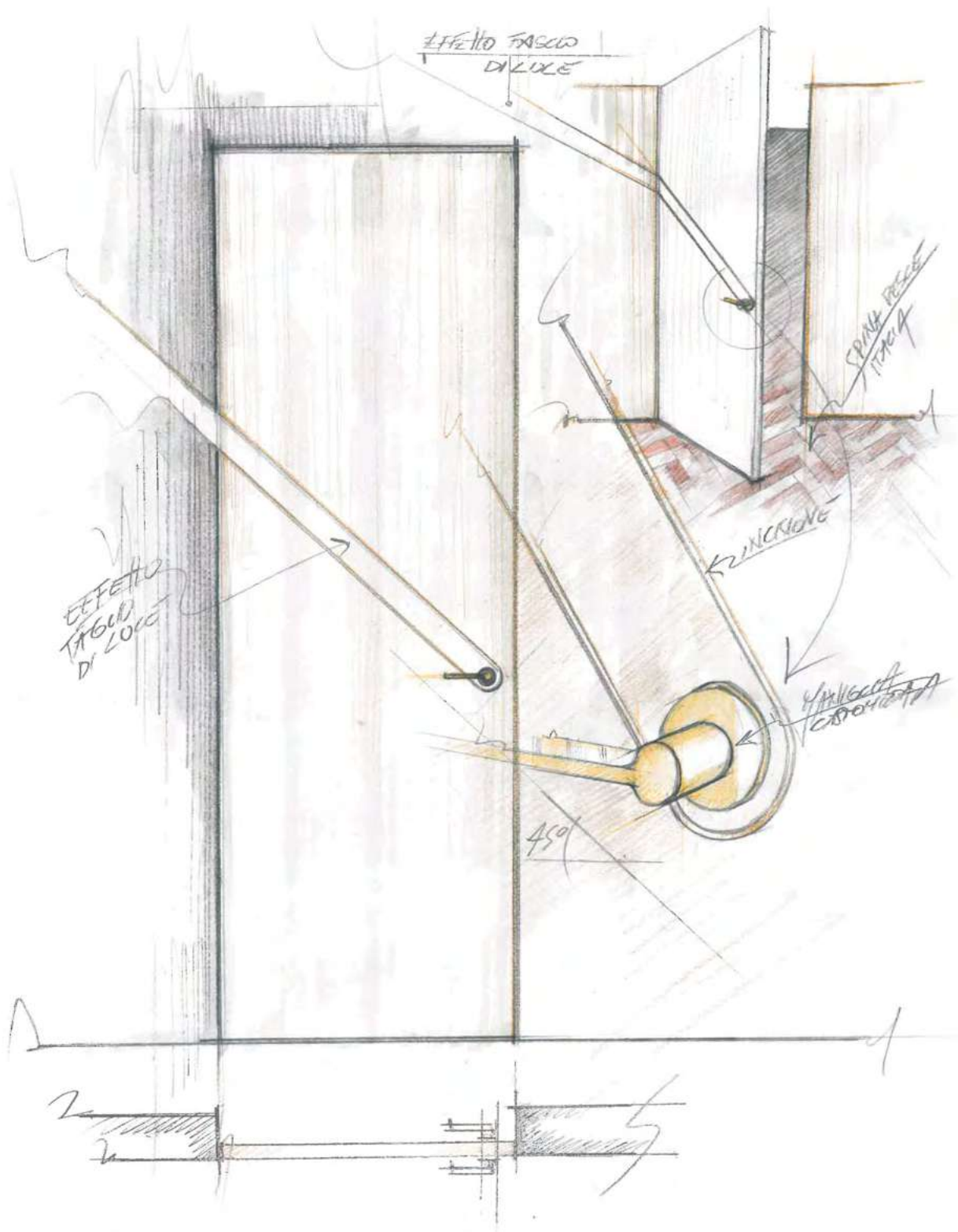



**STILE INCISA /
ENGRAVED STYLE**
**Serie Orbita /
Orbita Series**
model 441
laccato opaco /
matt lacquered
basalto



**STILE INCISA /
ENGRAVED STYLE**
**Serie Orbita /
Orbita Series**
model 443
laccato opaco /
matt lacquered
cashmere

**STILE INCISA /
ENGRAVED STYLE**
**Serie Orbita /
Orbita Series**
model 440
laccato opaco /
matt lacquered
ardesia



**STILE INCISA /
ENGRAVED STYLE**
**Serie Orbita /
Orbita Series**
model 442
laccato opaco /
matt lacquered
canapa



Serie Meridiana / *Meridiana Series*

Design by
Michele Marcon

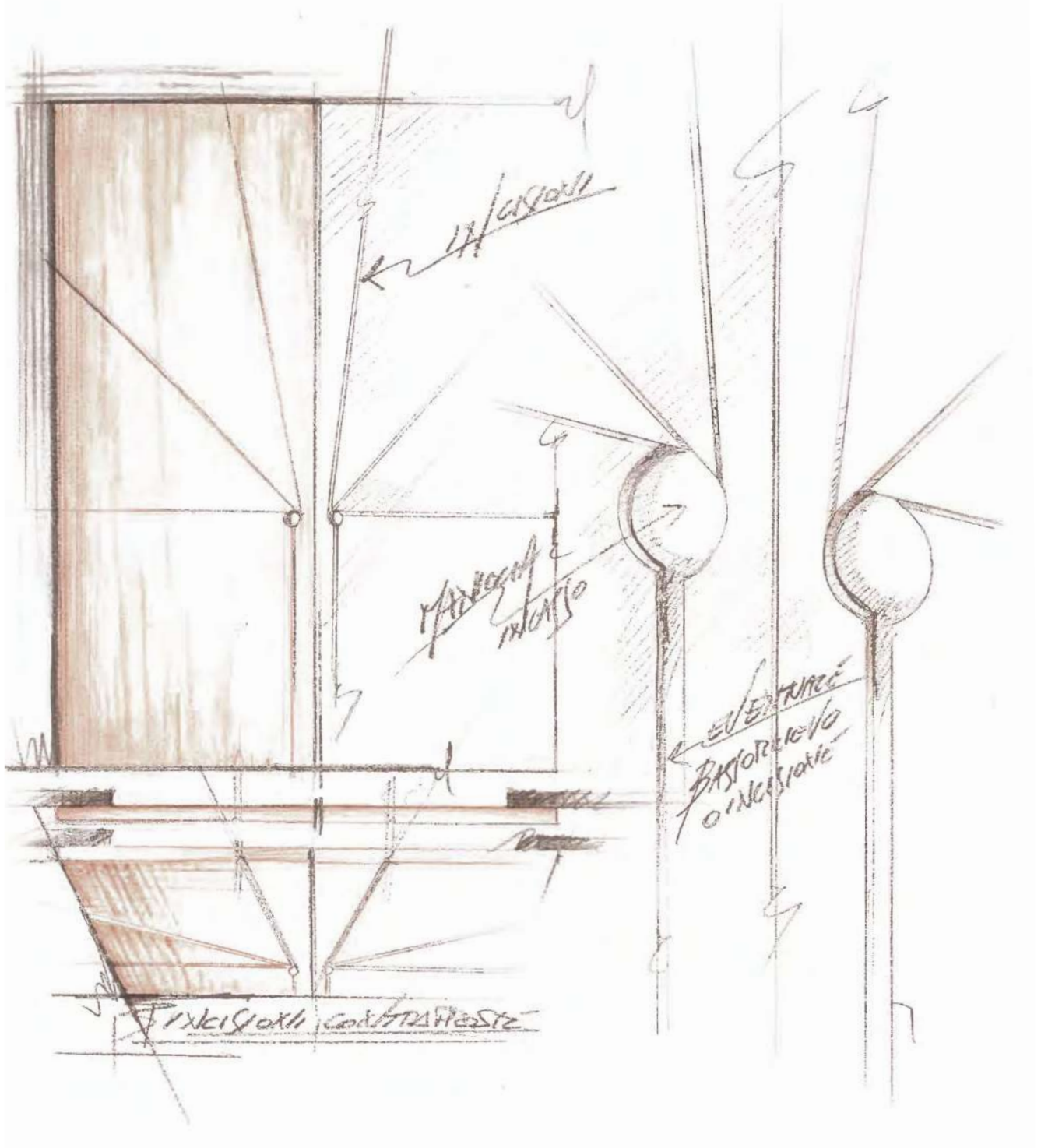

**STILE CON BASSORILIEVO /
WITH BAS-RELIEF MOTIF STYLE**

**Serie Meridiana /
Meridiana Series**

model 580

laccato opaco /
matt lacquered
cashmere



**STILE CON BASSORILIEVO /
WITH BAS-RELIEF MOTIF STYLE**

**Serie Meridiana /
Meridiana Series**

model 581

laccato opaco /
matt lacquered
canapa



**STILE CON BASSORILIEVO /
WITH BAS-RELIEF MOTIF STYLE**

**Serie Meridiana /
Meridiana Series**

model 582

laccato opaco /
matt lacquered
basalto



**STILE CON BASSORILIEVO E
INCISIONE / WITH BAS-RELIEF
AND ENGRAVED MOTIF STYLE**

**Serie Meridiana /
Meridiana Series**

model 610

laccato opaco /
matt lacquered
ardesia



Michele Marcon

DESIGNER



RICONOSCIMENTI / AWARDS



THE CHICAGO
ATHENAEUM
MUSEUM OF
ARCHITECTURE
AND DESIGN
2015

grandesignEtico 

La valenza estetica di un oggetto può colpire gli occhi e il cuore, ma solo quando la sua armonia formale sposa una precisa funzione l'oggetto diventa immortale.

Esso si tramuta in un bene di pubblico consumo, poiché tutti devono usufruire liberamente e coscientemente della bellezza e dell'utilità.

È a questo che il design deve mirare.

The aesthetic value of an object can strike eyes and heart, but it is only when its formal harmony marries a precise function of the object that it becomes immortal.

It is transformed into a public consumption commodity, since everyone must freely and conscientiously enjoy its beauty and usefulness.

And this is what design has to aim for.

Nato nel 1970, frequenta la specializzazione in arti grafiche, per poi diplomarsi dapprima in maestro d'arte e poi in grafico pubblicitario presso la scuola artistica M. Fanoli di Cittadella (PD).

Frequenta corsi di specializzazione in industrial ed interior design, lavorando contemporaneamente con show room del settore. Entra in contatto con lo studio Lino Codato designer con il quale avvia una collaborazione ventennale che gli dà la possibilità di avere una conoscenza a 360° in tutti i settori del mobile e dell'architettura d'interni, rafforzando così il proprio bagaglio culturale. Nel 2008, intraprende la libera professione, continuando a proporre idee di progettazione innovative ed armoniche che possano soddisfare le esigenze del cliente e del committente.

Born in 1970, he attended the specialized school in graphic art; he firstly graduated as Maestro d'Arte and then as Advertising Designer at "M. Fanoli" school in Cittadella (Padua).

He attended specialised courses in industrial and interior design while working with branch showrooms. After knowing Lino Codato design studio, he started with him a 20-year long collaboration, which gave him the opportunity to reach a 360° wide experience about furniture and interior design, thus reinforcing his cultural background.

In year 2008 he started working as a freelance, thus keeping on proposing innovative design and harmonic ideas which can satisfy the client requirements.

GALLERY

MANIGLIE SCAVATE

GUIDA

COLLEZIONI

PLUS

COMPLEMENTI

L'AZIENDA



Finiture e colori

Finishes and colours

LEGNI SPAZZOLATI

LACCATO OPACO

FRASSINO LACCATO PORO APERTO

FRASSINO LACCATO SPAZZOLATO

YELLOW PINE LACCATO SPAZZOLATO

Legni spazzolati / *Brushed woods*

Rovere bianco spazzolato, Rovere grigio spazzolato e Olmo brandy spazzolato.
Il legno e le sue venature sono protagonisti di questa finitura di grande personalità.
Scegli tra i colori disponibili.

*Brushed white oak, Brushed gray oak and Brushed brandy elm. The wood and its textures are the protagonists of this finish of great personality.
Choose among the available colours.*

Rovere bianco spazzolato *Brushed white oak*



Rovere grigio spazzolato
Brushed gray oak



Olmo brandy spazzolato
Brushed brandy elm



I campioni colori sono indicativi, possono differire dall'originale.
Per abbinamenti colori e finiture con collezioni vedere listino.

Colors for reference only, may vary from originals. For collections matching, see price list.

Laccato opaco / *Matt lacquered*

Questa finitura si adatta perfettamente all'ambiente, accordandosi all'arredamento, allo stile, ai colori stessi della tua casa. Scegli tra i colori disponibili.

This finish fits perfectly into the environment, matching the décor, style and colours of your home. Choose among the available colours.

Esempio di finitura Laccato opaco e colore Corda.
Example of Matt lacquered finish and Corda colour.

PURI
PURE

Bianco Pivato

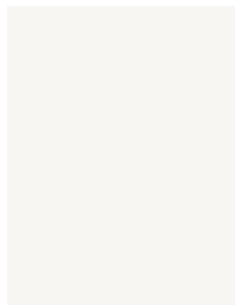

Bianco candido

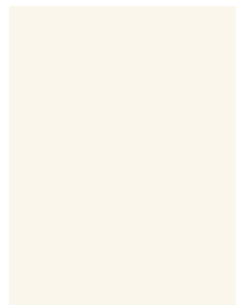

Panna

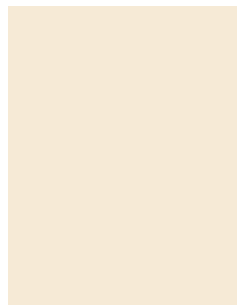

Avorio

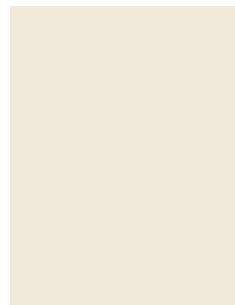

TERRA
EARTH

Corda

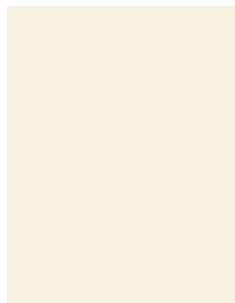

Sabbia

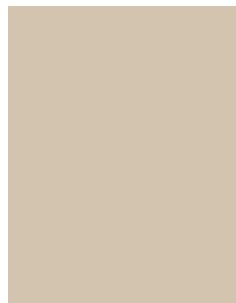

Beige

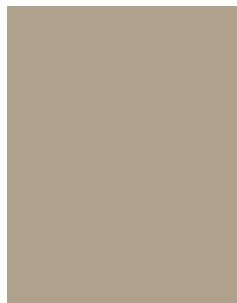

Canapa



Cashmere



URBANI
URBAN

Perla

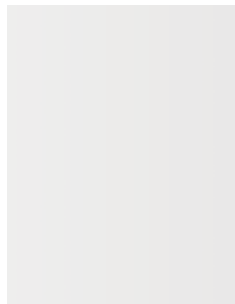

Ghiaia



Cadetto



Basalto



Ardesia



NATURA
NATURE

Tortora



Agata



Muschio



Salvia

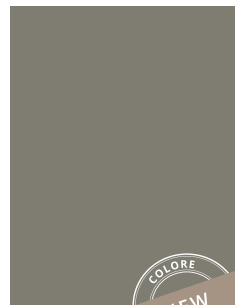

I campioni colori sono indicativi, possono differire dall'originale.
Per abbinamenti colori e finiture con collezioni vedere listino.

Colors for reference only, may vary from originals. For collections matching, see price list.

Frassino laccato poro aperto / *Open pore lacquered ash wood*

La decisione del frassino e la gentilezza della laccatura si incontrano in questa finitura speciale, sottolineando la matericità della tua porta Pivato.

Scegli tra i colori disponibili.

The boldness of ash and the gentleness of lacquer combine in this special finish, which emphasises the materiality of your Pivato door.

Choose from the available colours.



Esempio di finitura Frassino laccato poro aperto e colore Corda.
Example of Open pore lacquered ash wood finish and Corda colour.

PURI
PURE

Bianco Pivato



Bianco candido

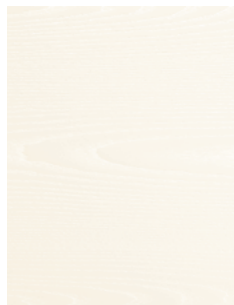

Panna



Avorio



TERRA
EARTH

Corda



Sabbia



Beige



Canapa

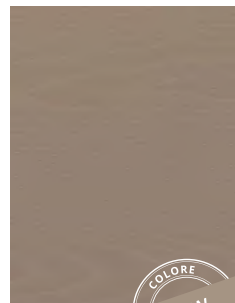

Cashmere

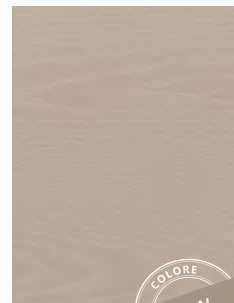

URBANI
URBAN

Perla

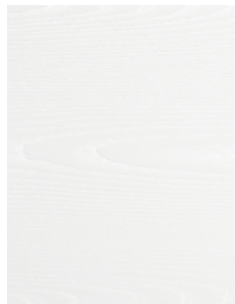

Ghiaia



Cadetto



Basalto



Ardesia



NATURA
NATURE

Tortora



Agata



Muschio



Salvia



I campioni colori sono indicativi, possono differire dall'originale.
Per abbinamenti colori e finiture con collezioni vedere listino.

Colors for reference only, may vary from originals. For collections matching, see price list.

Frassino laccato spazzolato / *Brushed lacquered ash wood*

Questa finitura che esalta la forza del frassino, è la soluzione per chi vuole una porta dalla personalità energica, ma che esprima al tempo stesso una grande eleganza, grazie alla tecnica della spazzolatura.

Scegli tra i colori disponibili.

This finish enhances the strength of the ash: it is the ideal choice for those who want a door with an energetic personality, but at the same time expressing great elegance, thanks to the brushing technique.

Choose from the available colours.



Esempio di finitura Frassino laccato spazzolato e colore Corda.
Example of Brushed lacquered ash wood finish and Corda colour.

PURI
PURE

Bianco Pivato



Bianco candido

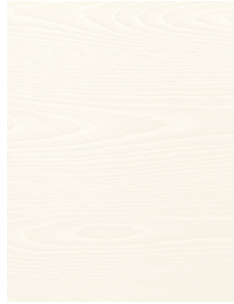

Panna



Avorio



TERRA
EARTH

Corda

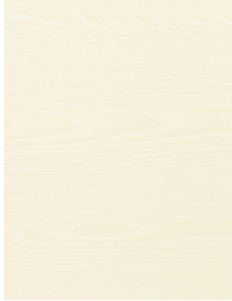

Sabbia



Beige



Canapa

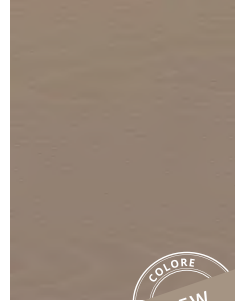

Cashmere



URBANI
URBAN

Perla



Ghiaia



Cadetto



Basalto



Ardesia



NATURA
NATURE

Tortora



Agata



Muschio



Salvia



I campioni colori sono indicativi, possono differire dall'originale.
Per abbinamenti colori e finiture con collezioni vedere listino.

Colors for reference only, may vary from originals. For collections matching, see price list.

Yellow Pine laccato spazzolato / *Brushed lacquered Yellow Pine*

Questa finitura porta in casa tua il pino giallo e le sue venature caratteristiche, capaci, grazie alla varietà di colori che proponiamo, di rendere gli ambienti di casa tua unici e inconfondibili.

L'aspetto di questa essenza, così rigata e scavata, ha costituito la fortuna di questo legno: infatti questa soluzione è spesso scelta da architetti e professionisti, che ne apprezzano l'utilizzo tecnico e le soluzioni moderne in ambito di design.

Scegli tra i colori disponibili.

This finish brings yellow pine and its characteristic grains into your home, which, thanks to the variety of colours we offer, can make your home unique and unmistakable.

The appearance of this wood, so grooved and hollowed out, has made the fortune of this wood: in fact, this solution is often chosen by architects and professionals, who appreciate its technical use and modern design solutions.

Choose from the available colours.



Esempio di finitura Yellow Pine laccato spazzolato e colore Corda.
Example of brushed lacquered Yellow Pine finish and Corda colour.

PURI
PURE

Bianco Pivato

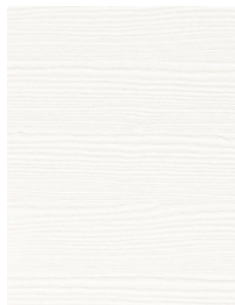

Bianco candido

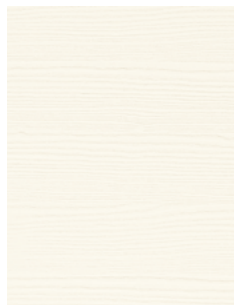

Panna

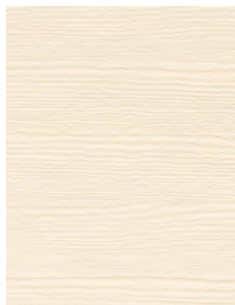

Avorio

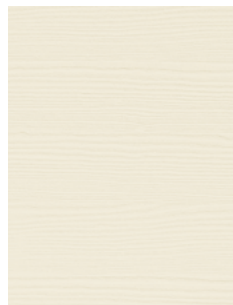

TERRA
EARTH

Corda

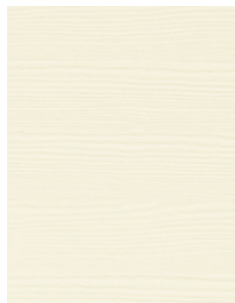

Sabbia



Beige



Canapa



Cashmere



URBANI
URBAN

Perla

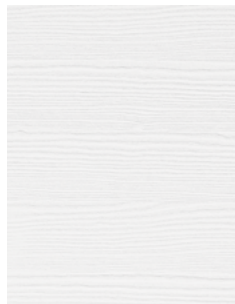

Ghiaia



Cadetto



Basalto



Ardesia



NATURA
NATURE

Tortora



Agata



Muschio



Salvia



I campioni colori sono indicativi, possono differire dall'originale.
Per abbinamenti colori e finiture con collezioni vedere listino.

Colors for reference only, may vary from originals. For collections matching, see price list.

Aperture *Openings*

In base allo spazio a disposizione e alla funzionalità della porta si possono scegliere sei tipologie di apertura.

You can choose from six different opening systems depending on the existing clearance requirements and the door function.



**ALTEZZA MANIGLIA PERSONALIZZATA A 980 mm /
CUSTOMISED HANDLE HEIGHT AT 980 mm**

- maniglia H 980 mm
- migliora l'ergonomia
- migliora l'estetica
- slancia la porta

- *handle H 980 mm*
- *improves ergonomics*
- *improves aesthetics*
- *slims the door*



ALTEZZA 980 mm / HEIGHT 980 mm

Con Pivato qualsiasi soluzione ha altezza 980 mm.

Handles and plates at the same height of 980 mm throughout the house.



BATTENTE / HINGED DOOR

- apertura tradizionale
- possibilità di scegliere tra una e due ante
- soluzione con maggiore isolamento acustico
- *traditional opening*
- *available with single leaf or two leaves*
- *solution with greater acoustic insulation*

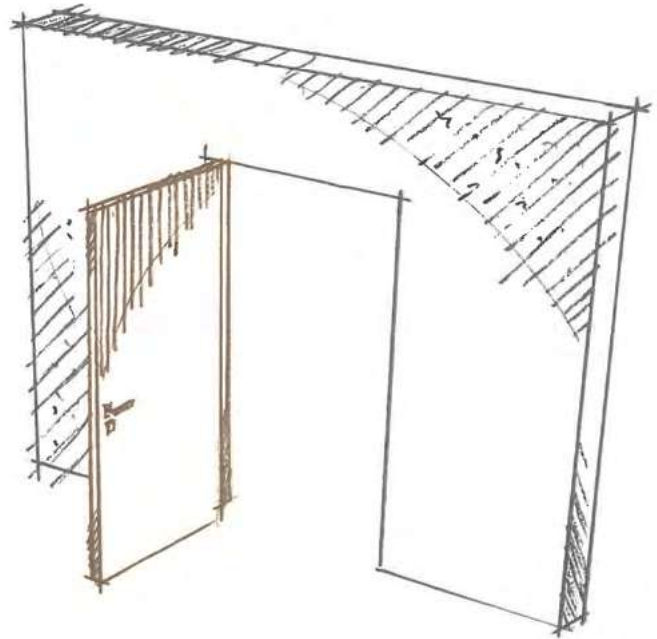

CABINA ARMADIO / WALK-IN CLOSET DOOR

- vari tipi di utilizzo come chiudere nicchie, cappelliere, dispense
- soluzione a spingere
- possibilità di scegliere tra una e due ante
- *various uses such as niches, overhead compartments, storage rooms*
- *push and pull solution*
- *available with single leaf or two leaves*

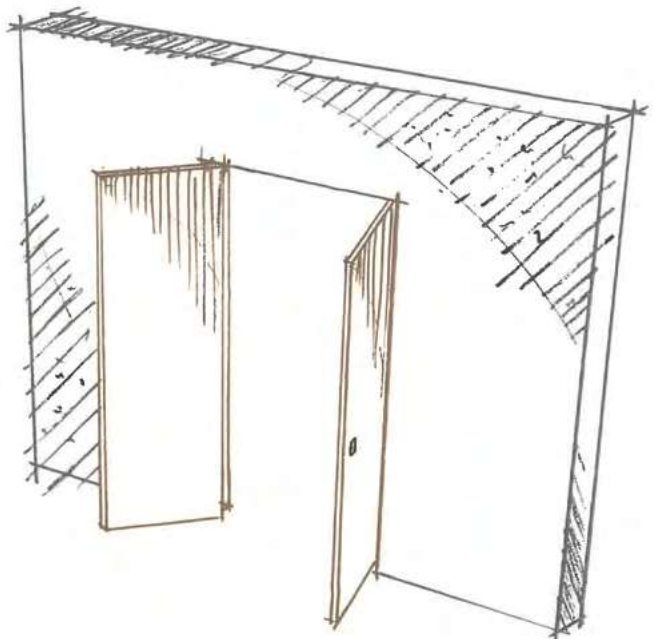

A LIBRO / *FOLDING DOOR*

- costituita da due ante uguali che si piegano
- ideale per chiudere spazi ridotti come ripostigli bagni e servizi
- massima accessibilità con minimo ingombro
- *consisting of two identical folding panels*
- *ideal for enclosing small spaces such as storage rooms and restrooms*
- *maximum accessibility with minimal clearance requirements*

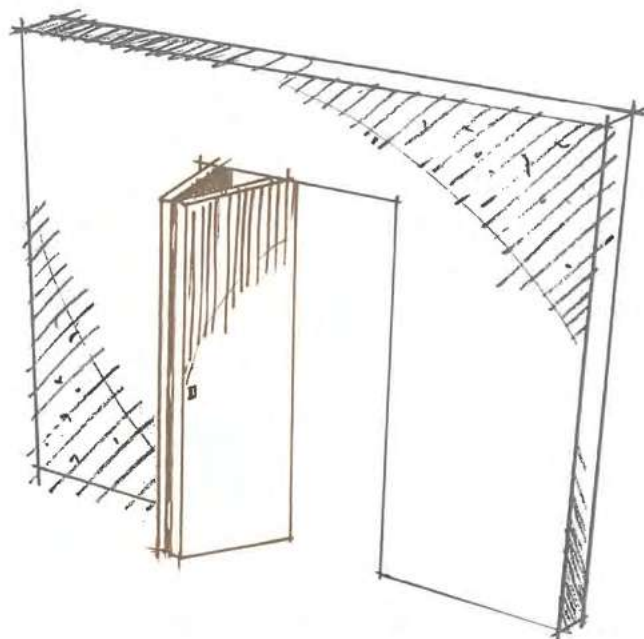

ROTOTRASLANTE / *PIVOT SLIDING DOOR*

- apribile in entrambe le direzioni
- soluzione innovativa
- facilità di passaggio
- *openable in both directions*
- *innovative solution*
- *ease of transit*

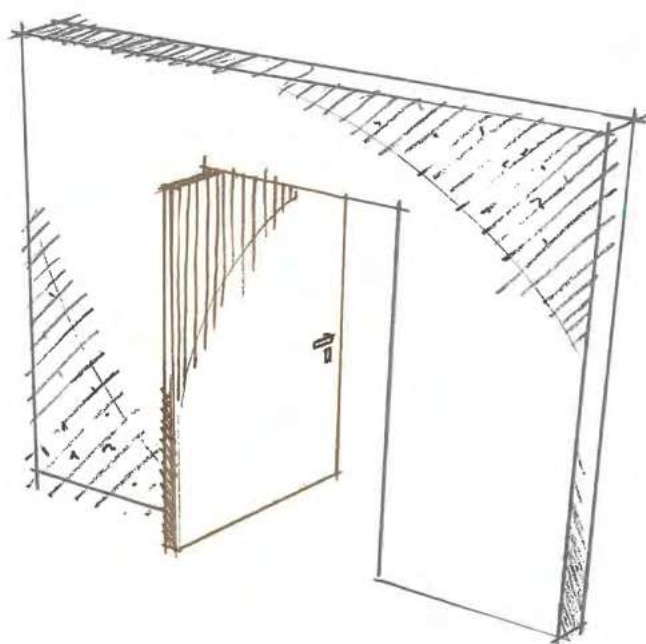

SCORREVOLE ESTERNO MURO / EXTERNAL SLIDING DOOR

- comoda se non si vogliono fare lavori di muratura
- elemento d'arredo, diventa quasi una parete in movimento
- possibilità di scegliere tra una e due ante
- *ideal to avoid masonry work*
- *decor element, it almost becomes a moving wall*
- *available with single leaf or two leaves*

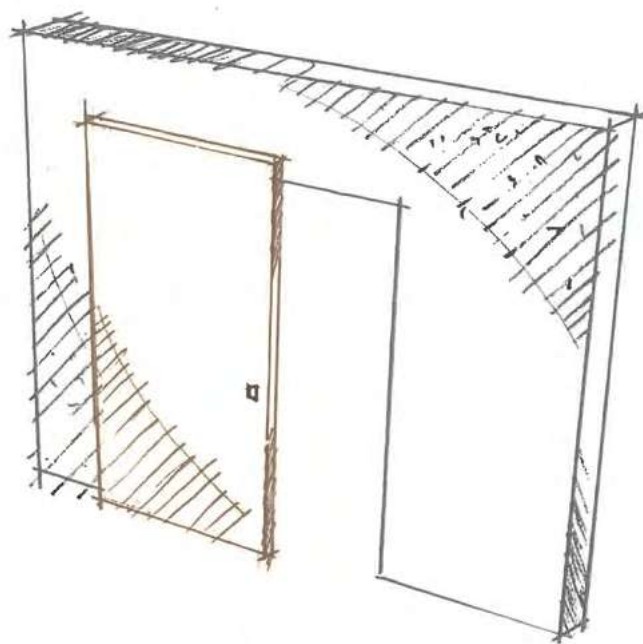

SCORREVOLE INTERNO MURO / INNER WALL SLIDING DOOR

- risolve il problema dello spazio ridotto
- lascia libera la parete
- elimina l'ingombro dell'anta nella stanza
- *solves the problem of reduced space*
- *leaves the wall unencumbered*
- *eliminates leaf clearance requirements in the room*

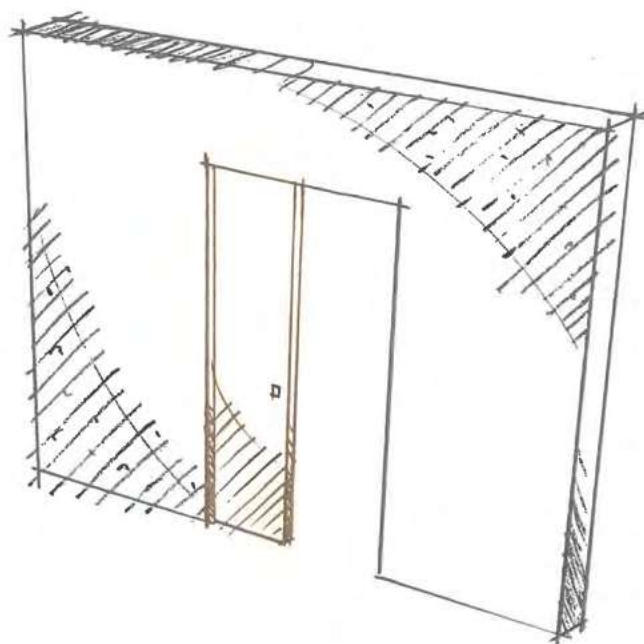

Apertura Silenzio

Silenzio opening

Abbiamo rivoluzionato l'apertura delle porte.

Con l'apertura Silenzio il modo di aprire una porta cambierà per sempre. La funzionalità sposa un design avanzato ed essenziale, dove la maniglia diventa superflua.

We have revolutionized the way we open doors.

The Silenzio mechanism will forever change the way we open doors. Functionality marries an advanced and essential design, where the handle becomes redundant.

**APERTURA SILENZIO:
L'UNICA CHE SI APRE SENZA
IMPUGNARE LA MANIGLIA**

Con l'apertura Silenzio non c'è più bisogno di usare la mano per agire sulla maniglia, la porta potrà essere aperta anche con ambedue le mani impegnate! Soluzione disponibile per porta battente e cabina armadio, su tutte le collezioni.

**SILENZIO OPENING:
THE ONLY ONE THAT OPENS
WITHOUT USING THE HANDLE**

The Silenzio mechanism eliminates the need to operate a door handle by hand; now, the door can be opened even with both hands full!

Solution available for swing doors and walk-in closet doors, on all collections.



Guarda il video
See the video



Vista esterno ambiente
Room external view

Apertura Rototraslante

Pivot sliding opening

Mentre la porta viene aperta l'asta dell'anta scorre su un binario permettendo l'apertura in entrambi i sensi.

È una soluzione innovativa per facilitare il passaggio da un ambiente all'altro.

While opening the door, the door leaf pin slides along a rail so the door can be opened in both directions.

It is an innovative solution to facilitate passing from one room to another.



Guarda il video
See the video



GUIDA
aperture

Vista esterno ambiente
Room external view



Particolare binario incassato sul traverso dello stipite
Detail of the insert track on the header of the jamb



Braccio inferiore e particolare scasso stipite
Lower arm and detail of locking-picking jamb



Serratura magnetica e spazzolini
Magnetic lock and brushes

Particolare stipite lato incontro
Detail of jamb locking side



Collezioni

Collections

CON COPRIFILO
TELESCOPICO

CON STIPITE
SU MISURA

VIVACE

OPERA50

VIVACE

DINAMICA

UNICA

INVERSA

LEGGERA

SCORREVOLI SPECIAL



Vivace

con stipite su misura e
coprifilo telescopico

(p. 212)

CARATTERISTICHE:

- complanarità anta-coprifilo, interno stanza
- anta con telaio in legno di abete giuntato a pettine e stipite in listellare di abete
- incastro coprifilo/stipite a pettine
- personalizzabile nelle misure

ANTA:

- spessore 40 mm
- 1 tirante di registrazione, lato maniglia
- anta rivestita sui 4 bordi
- anta reversibile destra-sinistra

STIPITE:

- su misura "passo 15 mm" fino a muri di 580 mm
- spessore 33 mm con battuta 12 mm
- stipite reversibile destro-sinistro
- guarnizione in 5 colori

COPRIFILO:

- multistrato di pioppo rivestito
- coprifilo telescopico - esterno stanza
- coprifilo dritto - interno stanza

ACCESSORI:

- serratura magnetica con incontro regolabile
- cerniere a bilico invisibile registrabile in acciaio
- cover in grigio alluminio - di serie
- kit accessori colore nero - optional

TIPOLOGIA DI APERTURA:

- porta battente - 110°
- cabina armadio
- porta rototraslante
- scorrevole esterno muro
- scorrevole interno muro

ALTEZZA:

fino a 2100 mm (misura nominale)



Opera50

con stipite su misura e
coprifilo telescopico

(p. 218)

CARATTERISTICHE:

- complanarità anta-coprifilo lato esterno stanza
- anta con telaio in legno di abete giuntato a pettine e stipite in listellare di abete
- GHOST profilo in alluminio estruso (apertura a SPINGERE)
- incastro coprifilo/stipite a pettine (apertura a TIRARE)
- personalizzabile nelle misure

N.B. Il punto di giunzione tra pavimenti diversi deve essere esterno stanza

ANTA:

- spessore 56 mm
- 2 tiranti di registrazione - optional
- anta rivestita sui 4 bordi

STIPITE:

- su misura "passo 15 mm" fino a muri di 580 mm
- spessore 33 mm con battuta 12 mm
- stipite reversibile destro-sinistro (apertura a SPINGERE)
- guarnizione in 5 colori

COPRIFILO:

- multistrato di pioppo rivestito
- coprifilo telescopico - interno stanza
- coprifilo piatto - esterno stanza

ACCESSORI:

- serratura magnetica con incontro regolabile
- cerniere a scomparsa registrabili su 3 assi - di serie
- cover dello stesso colore dell'anta - di serie
- kit accessori colore nero - optional

TIPOLOGIA DI APERTURA:

- porta a battente
 - 90° - a spingere
 - 180° - a tirare

ALTEZZA:

personalizzabile in altezza



Vivace con stipite su misura

(p. 224)

CARATTERISTICHE:

- complanarità anta-coprifilo, interno stanza
- anta con telaio in legno di abete giuntato a pettine e stipite in listellare di abete
- incastro coprifilo/stipite a pettine
- personalizzabile nelle misure

ANTA:

- spessore 40 mm
- 1 tirante di registrazione, lato maniglia
- anta rivestita sui 4 bordi
- anta reversibile destra-sinistra

STIPITE:

- su misura fino a muri di 580 mm
- spessore 33 mm con battuta 12 mm
- guarnizione in 5 colori

COPRIFILO:

- multistrato di pioppo rivestito

ACCESSORI:

- serratura magnetica con incontro regolabile
- cerniere a pomella
- cerniere a bilico

TIPOLOGIA DI APERTURA:

- porta battente - 180°
- cabina armadio
- porta rototraslante
- scorrevole esterno muro
- scorrevole interno muro

ALTEZZA:

fino a 2100 mm (misura nominale)



Dinamica con stipite su misura

(p. 230)

CARATTERISTICHE:

- l'anta rientra leggermente rispetto al coprifilo
- anta con telaio in legno di abete giuntato a pettine e stipite in listellare di abete
- incastro coprifilo/stipite a pettine
- personalizzabile nelle misure

ANTA:

- spessore 40 mm
- 1 tirante di registrazione, lato maniglia
- anta rivestita sui 4 bordi

STIPITE:

- su misura fino a muri di 580 mm
- spessore 33 mm con battuta 12 mm
- guarnizione in 5 colori

COPRIFILO:

- multistrato di pioppo rivestito
- coprifilo inclinato con apertura 135° - di serie
- coprifilo dritto con apertura 105° - di serie
- coprifilo classico con apertura 110° - optional
- coprifilo barocco con apertura 110° - optional

ACCESSORI:

- serratura magnetica con incontro regolabile
- cerniere a scomparsa registrabili su 3 assi
- cover dello stesso colore dell'anta - di serie
- kit accessori colore nero - optional

TIPOLOGIA DI APERTURA:

- porta battente
- cabina armadio
- porta a libro
- porta rototraslante
- scorrevole esterno muro
- scorrevole interno muro

ALTEZZA:

personalizzabile in altezza



Unica con stipite su misura

(p. 236)

CARATTERISTICHE:

- complanarità anta-coprifilo lato interno stanza
- anta con telaio in legno di abete giuntato a pettine e stipite in listellare di abete
- personalizzabile nelle misure

ANTA:

- spessore 40 mm
- spessore 56 mm - optional
- 1 tirante di registrazione, lato maniglia (anta 40 mm)
- 2 tiranti di registrazione - optional (anta 56 mm)
- anta rivestita sui 4 bordi

STIPITE:

- su misura fino a muri di 580 mm
- spessore 33 mm con battuta 12 mm
- guarnizione in 5 colori

COPRIFILO:

- multistrato di pioppo rivestito

ACCESSORI:

- serratura magnetica con incontro regolabile
- cerniere a scomparsa registrabili su 3 assi
- cover dello stesso colore dell'anta - di serie
- kit accessori colore nero - optional

TIPOLOGIA DI APERTURA:

- porta a battente
- cabina armadio
- porta a libro
- porta rototraslante
- scorrevole esterno muro
- scorrevole interno muro

ALTEZZA:

personalizzabile in altezza



Inversa con stipite su misura

(p. 242)

CARATTERISTICHE:

- complanarità anta-coprifilo, esterno stanza
- anta con telaio in legno di abete giuntato a pettine e stipite in listellare di abete
- personalizzabile nelle misure

N.B. Il punto di giunzione tra pavimenti diversi deve essere esterno stanza

ANTA:

- spessore 56 mm
- 2 tiranti di registrazione - optional
- anta rivestita sui 4 bordi

STIPITE:

- su misura fino a muri di 580 mm
- spessore 33 mm con battuta 12 mm
- guarnizione in 5 colori

COPRIFILO:

- multistrato di pioppo rivestito

ACCESSORI:

- serratura magnetica con incontro regolabile
- cerniere a scomparsa registrabili
- cover dello stesso colore dell'anta - di serie
- kit accessori colore nero - optional

TIPOLOGIA DI APERTURA:

- porta a battente

ALTEZZA:

personalizzabile in altezza



Leggera

(p. 248)

CARATTERISTICHE:

- complanarità anta filo muro esterno stanza
- non ha stipite, ha un nucleo in alluminio estruso unico per muratura o cartongesso, brevetto Pivato
- personalizzabile nelle misure

N.B. Il punto di giunzione tra pavimenti diversi deve essere esterno stanza

ANTA:

- anta in legno di abete giuntato a pettine rivestita
- spessore 40 mm
- spessore 56 mm - optional
- 1 tirante di registrazione, lato maniglia (anta 40 mm)
- 2 tiranti di registrazione - optional (anta 56 mm)
- anta rivestita sui 4 bordi

L'anta può essere tinteggiata o rivestita come la parete.

NUCLEO:

- profilo rigido grazie alle anime di spessore di circa 2 mm, questo deve essere posato contestualmente alle pareti
- disponibile in alluminio verniciabile o bianco
- OPTIONAL - predisposizione battiscopa a filo muro
- personalizzabile nelle misure adatto a qualsiasi spessore muro

ACCESSORI:

- serratura magnetica con incontro regolabile
- cerniere a scomparsa, registrabili su 3 assi
- cover in grigio alluminio di serie
- kit accessori colore nero - optional

TIPOLOGIA DI APERTURA:

- porta a battente
 - 90° - a spingere
 - 180° - a tirare

ALTEZZA:

fino al soffitto H 3000 mm previa verifica fattibilità modello / finitura / dimensioni



Scorrevoli Special

(p. 254)

CARATTERISTICHE SISTEMI DI SCORRIMENTO:

- Minimal Soft Pro
- Alchemy
- Feeling
- Linear20
- Basic
- Light

ANTA:

- anta in legno di abete giuntato a pettine rivestita
- spessore 40 mm
- 1 tirante di registrazione, lato placca
- anta rivestita sui 4 bordi

ALTEZZA:

fino a 3000 mm previa verifica fattibilità modello / finitura / dimensioni

Vivace

con stipite su misura e coprifilo telescopico

Design e tradizione si fondono nella collezione Vivace. Un legame dato sia dalla sua linea pulita ed elegante che dalla sua funzionalità, garantita dalle caratteristiche che la definiscono: la complanarità perfetta sul lato interno stanza, il coprifilo telescopico, la possibilità di convertire il senso di apertura della porta da destra a sinistra e viceversa, così da facilitare l'imprevisto, e tutti i vantaggi tecnici che caratterizzano una vera porta Pivato.

The quality of the Vivace collection is linked both to its clean and elegant line and to its functionality, ensured by the features that define it: the perfect coplanarity inside the room, the telescopic casing, the possibility to convert the opening from right to left to facilitate the unexpected, and all the technical advantages that characterize a real Pivato door.

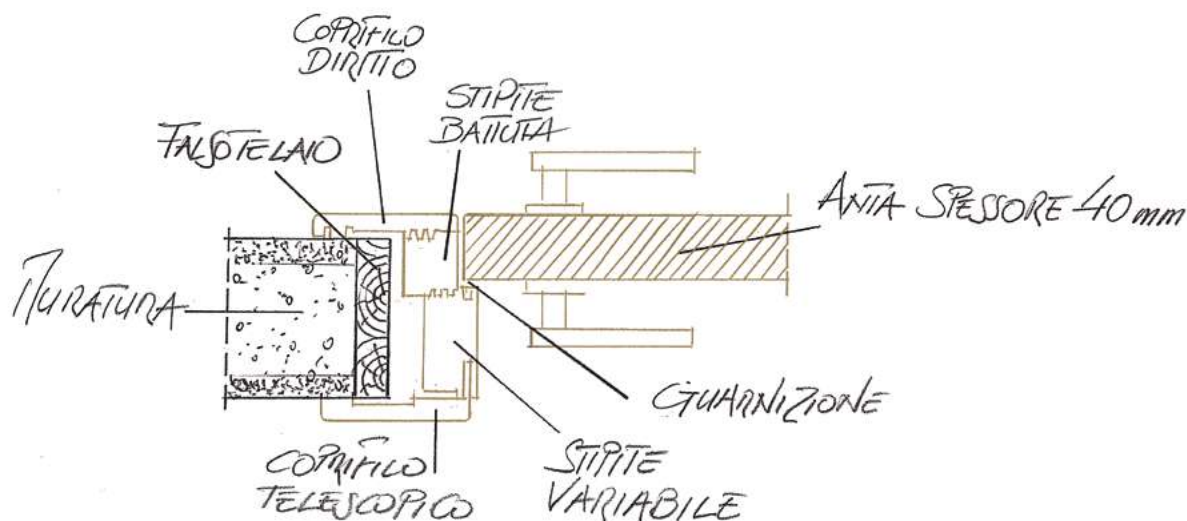

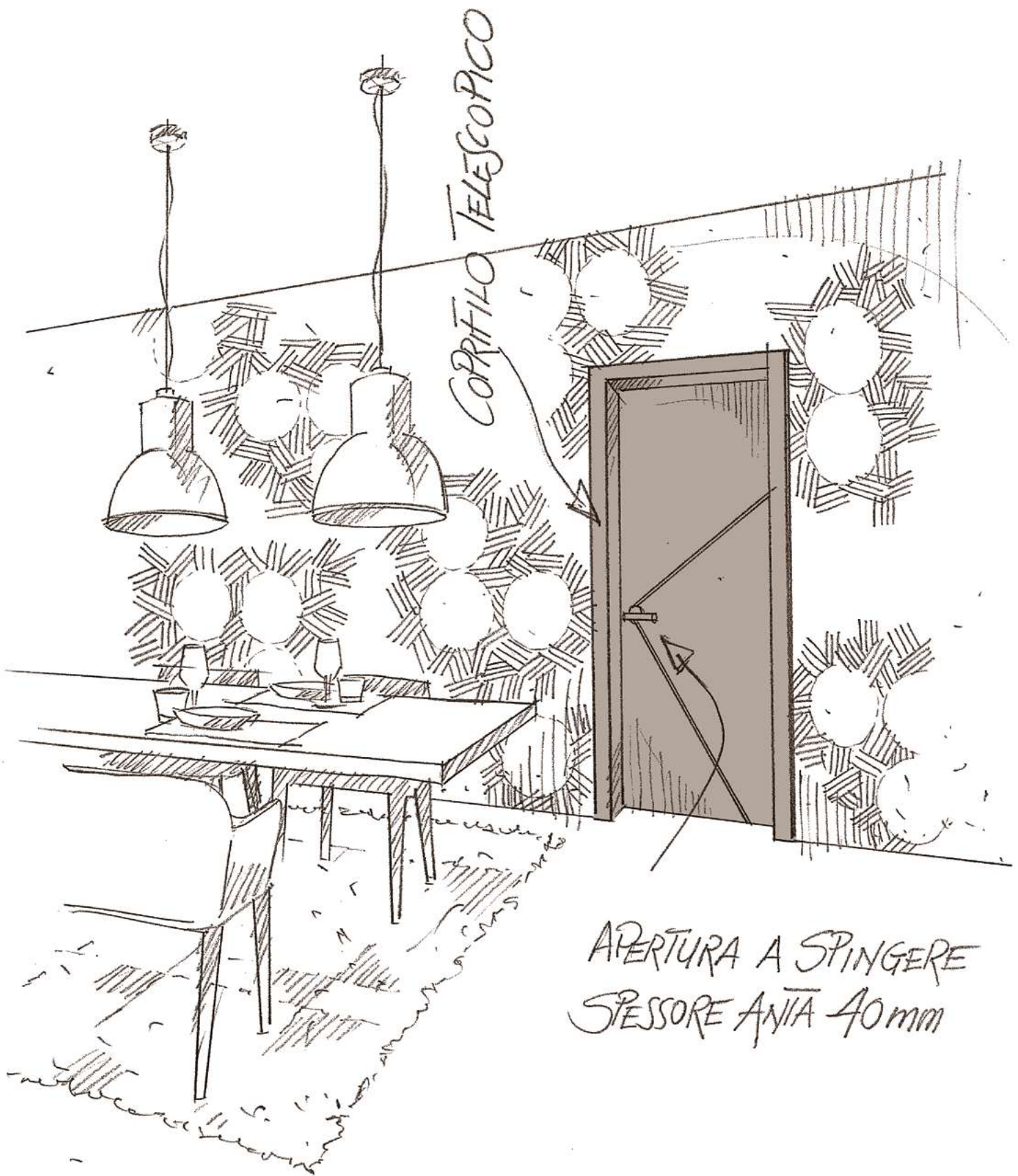

APERTURA A SPINGERE
SPESORE ANTA 40mm

Caratteristiche / *Features*

Vivace

con stipite su misura e coprifilo telescopico



CARATTERISTICHE:

- complanarità anta-coprifilo, interno stanza
- anta con telaio in legno di abete giuntato a pettine e stipite in listellare di abete
- incastro coprifilo/stipite a pettine
- personalizzabile nelle misure

ANTA:

- spessore 40 mm
- 1 tirante di registrazione, lato maniglia
- anta rivestita sui 4 bordi
- anta reversibile destra-sinistra

STIPITE:

- su misura "passo 15 mm" fino a muri di 580 mm
- spessore 33 mm con battuta 12 mm
- stipite reversibile destro-sinistro
- guarnizione in 5 colori

COPRIFILO:

- multistrato di pioppo rivestito
- coprifilo telescopico - esterno stanza
- coprifilo dritto - interno stanza

ACCESSORI:

- serratura magnetica con incontro regolabile
- cerniere a bilico invisibile registrabili in acciaio
- cover in grigio alluminio - di serie
- kit accessori colore nero - optional

TIPOLOGIA DI APERTURA:

- porta battente - 110°
- cabina armadio
- porta rototraslante
- scorrevole esterno muro
- scorrevole interno muro

ALTEZZA:

fino a 2100 mm (misura nominale)

FEATURES:

- coplanarity between door leaf and casing, inside the room
- finger-jointed fir frame and spruce blockboard jamb
- finger-jointed jamb/cover
- customisable measurements

DOOR LEAF:

- thickness 40 mm
- 1 adjustable tie rod, handle side
- four-side edging
- right-left reversible door

JAMB:

- "15 mm pitch" customised jamb for non-standard walls till 580 mm
- 33 mm thick with 12 mm stop
- right-left reversible jamb
- seal in 5 colours

CASING:

- multilayered poplar coated
- telescopic casing - outside room
- straight casing - inside room

ACCESSORIES:

- magnetic lock with adjustable striker
- invisible adjustable hinges in steel
- aluminum gray cover - standard equipment
- black accessories kit - optional

OPENING:

- hinged door - 110°
- walk-in closet door
- pivot sliding door
- external sliding door
- inner wall sliding door

HEIGHT:

up to 2100 mm (nominal size)

Tratti distintivi *Distinctive traits*

Vivace con stipite su misura e coprifilo telescopico

Grazie al
COPRIFILO TELESCOPICO
si adatta a diversi spessori
del muro in modo da soddisfare
qualsiasi esigenza.

Thanks to its
TELESCOPIC CASING,
it can be adapted to different
wall thicknesses to suit any
requirement.

È dotata di **2 CERNIERE
A BILICO INVISIBILI
REGISTRABILI**

Equipped with **2 INVISIBLE
ADJUSTABLE PIVOT
HINGES**

Scopri tutti i Plus delle Collezioni da pagina 275.
Discover all the Plus of the Collections from page 275.

Scopri la Collezione Vivace in alcuni dei nostri progetti ambientati.

Discover the Vivace Collection in some of our interior projects.



Opera50

con stipite su misura e
coprifilo telescopico



È nata una nuova sinfonia in casa Pivato.

Opera: un nome riconoscibile a livello internazionale, concepito per dare una continuità al marchio nato nel 1969.

50: come gli anni di esperienza che hanno permesso di creare una collezione di alto livello.

Con **Opera 50 capovolgiamo il concetto di apertura** nella Linea Legno: la collezione assicura la perfetta complanarità degli elementi sul lato esterno stanza, con soluzione a spingere e a tirare. Una collezione che al suo interno raccoglie numerose innovazioni tecniche e di materiali che la rendono solida e resistente senza rinunciare al design.

A new symphony was born in the "maison Pivato".

***Opera:** an internationally recognizable name, conceived to give continuity to the brand since 1969.*

***50:** like the years of experience that allowed us to create a high-level collection.*

***In the linea Legno we reverse the opening concept:** the collection Opera50 provided the perfect conformity of the elements on the priority side, with a push and pull solution. A collection that contains technical and material innovations that make it solid and resistant without sacrificing design.*

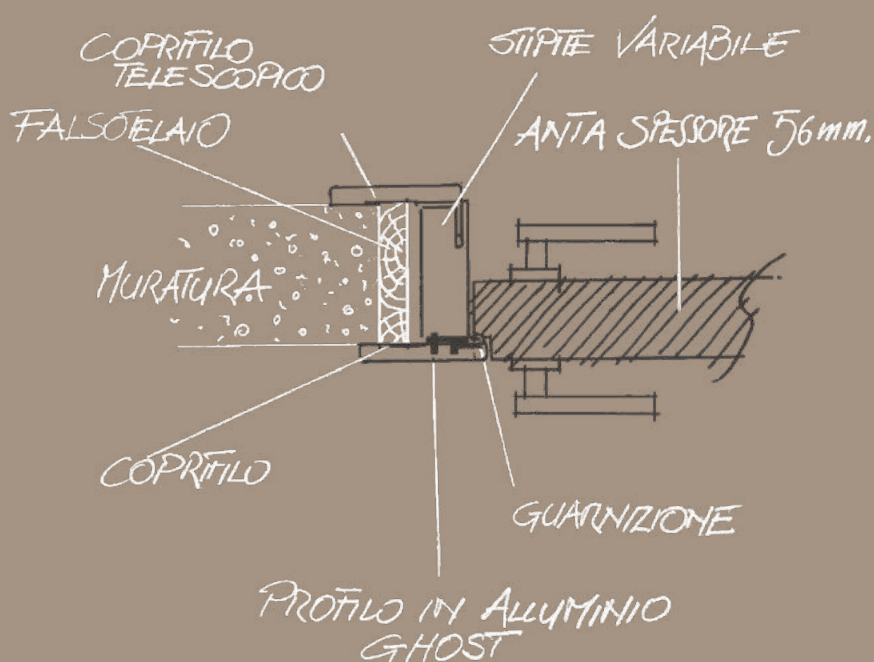



Caratteristiche / *Features*

Opera50

con stipite su misura e coprifilo telescopico



CARATTERISTICHE:

- complanarità anta-coprifilo lato esterno stanza
- anta con telaio in legno di abete giuntato a pettine e stipite in listellare di abete
- GHOST profilo in alluminio estruso, (apertura a SPINGERE)
- incastro coprifilo/stipite a pettine (apertura a TIRARE)
- personalizzabile nelle misure

N.B. Il punto di giunzione tra pavimenti diversi deve essere esterno stanza

ANTA:

- spessore 56 mm
- 2 tiranti di registrazione - optional
- anta rivestita sui 4 bordi

STIPITE:

- su misura "passo 15 mm" fino a muri di 580 mm
- spessore 33 mm con battuta 12 mm
- stipite reversibile destro-sinistro (apertura a SPINGERE)
- guarnizione in 5 colori

COPRIFILO:

- multistrato di pioppo rivestito
- coprifilo telescopico - interno stanza
- coprifilo piatto - esterno stanza

ACCESSORI:

- serratura magnetica con incontro regolabile
- cerniere a scomparsa, registrabili su 3 assi - di serie
- kit accessori colore nero - optional

TIPOLOGIA DI APERTURA:

- porta battente
- 90° - a spingere
- 180° - a tirare

ALTEZZA:

personalizzabile in altezza

FEATURES:

- coplanarity between door leaf and casing, outside the room
- finger-jointed fir frame and spruce blockboard jamb
- GHOST extruded aluminium profile (PUSH opening)
- finger-jointed jamb/cover (PULL opening)
- customisable measurements

N.B. The junction point between different floors must be outside the room.

DOOR LEAF:

- thickness 56 mm
- 2 adjustable tie rod - optional
- four-side edging

JAMB:

- "15 mm pitch" customised jamb for non-standard walls till 580 mm
- 33 mm thick with 12 mm stop
- right-left reversible jamb (PUSH opening)
- seal in 5 colours

CASING:

- multilayered poplar coated
- telescopic casing - inside room
- flat casing - outside room

ACCESSORIES:

- magnetic lock with adjustable striker
- concealed hinges, adjustable on 3 axes - standard equipment
- cover of the same color of the door leaf - standard equipment
- black accessories kit - optional

OPENING:

- hinged door
- 90° - pushing
- 180° - pulling

HEIGHT:

height customisable

Tratti distintivi *Distinctive traits*

Opera50 con stipite su misura e coprifilo telescopico

Permette la
COMPLANARITÀ
tra anta e coprifilo sul lato esterno
stanza con possibilità di scegliere
**SOLUZIONI A SPINGERE
O A TIRARE.**

Allows the **COMPLANARITY**
between door and casing on the
outside of the room with the
possibility of choosing
PUSH OR PULL SOLUTIONS.

Grazie al
COPRIFILO TELESCOPICO
si adatta a diversi spessori
del muro.

Thanks to the
TELESCOPIC CASING,
it adapts to different wall
thicknesses.

Scopri tutti i Plus delle Collezioni da pagina 275.
Discover all the Plus of the Collections from page 275.

Scopri la Collezione Opera50 in alcuni dei nostri progetti ambientati.

Discover the Opera50 Collection in some of our interior projects.

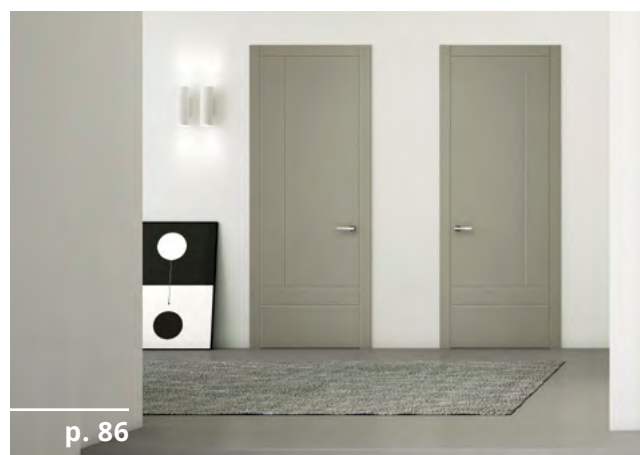

Vivace

con stipite su misura

Design e tradizione si fondono nella collezione Vivace. Un legame dato sia dalla sua linea pulita ed elegante che dalla sua funzionalità, garantita dalle caratteristiche che la definiscono: la complanarità perfetta sul lato interno stanza, la linearità dello stipite su misura, la possibilità di convertire il senso di apertura della porta da destra a sinistra e viceversa, così da facilitare l'imprevisto, e tutti i vantaggi tecnici che caratterizzano una vera porta Pivato.

The quality of the Vivace collection is linked both to its clean and elegant line and to its functionality, ensured by the features that define it: the perfect coplanarity on the inside of the room, the linearity of the custom-made jamb, the possibility to convert the opening from right to left to facilitate the unexpected, and all the technical advantages that characterize a real Pivato door.

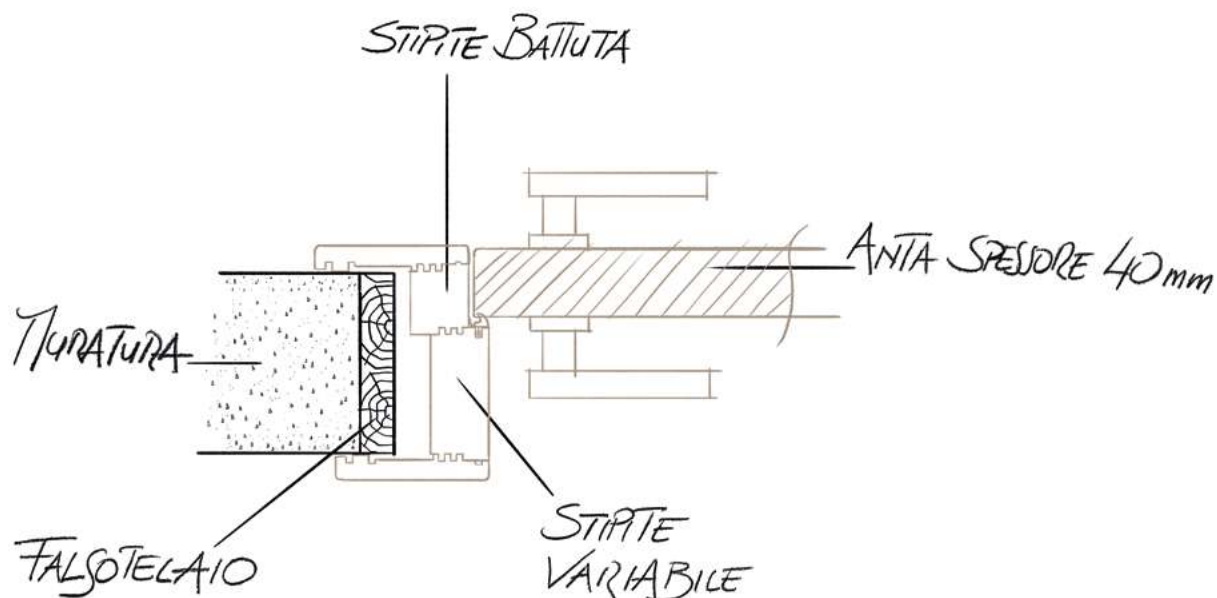

APERTURA A SPINGERE

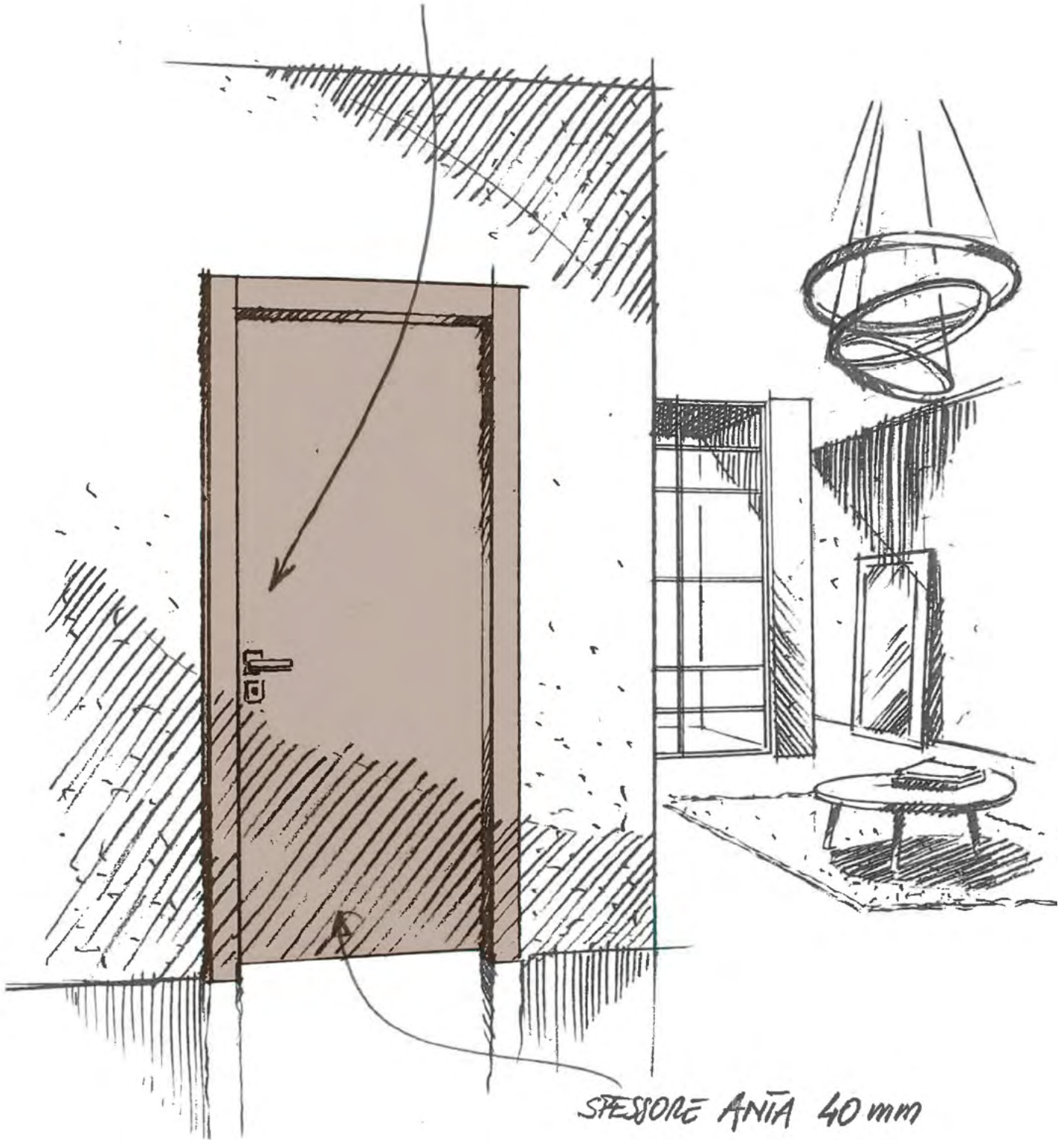

SPESORE ANIA 40 mm

Caratteristiche/*Features*

Vivace

con stipite su misura



CARATTERISTICHE:

- complanarità anta-coprifilo, interno stanza
- anta con telaio in legno di abete giuntato a pettine e stipite in listellare di abete
- incastro coprifilo/stipite a pettine
- personalizzabile nelle misure

ANTA:

- **spessore 40 mm**
- **1 tirante di registrazione, lato maniglia**
- **anta rivestita sui 4 bordi**
- **anta reversibile destra-sinistra**

STIPITE:

- **su misura fino a muri di 580 mm**
- **spessore 33 mm con battuta 12 mm**
- **guarnizione in 5 colori**

COPRIFILO:

- **multistrato di pioppo rivestito**

ACCESSORI:

- **serratura magnetica con incontro regolabile**
- **cerniere a pomella**
- **cerniere a bilico**

TIPOLOGIA DI APERTURA:

- porta battente - 180°
- cabina armadio
- porta rototraslante
- scorrevole esterno muro
- scorrevole interno muro

ALTEZZA:

fino a 2100 mm (misura nominale)

FEATURES:

- *coplanarity between door leaf and casing, inside the room*
- *finger-jointed fir frame and spruce blockboard jamb*
- *finger-jointed jamb/cover*
- *customisable measurements*

DOOR LEAF:

- **thickness 40 mm**
- **1 adjustable tie rod, handle side**
- **four-side edging**
- **right-left reversible door**

JAMB:

- **customised jamb for non-standard walls till 580 mm**
- **33 mm thick with 12 mm stop**
- **seal in 5 colours**

CASING:

- **multilayered poplar coated**

ACCESSORIES:

- **magnetic lock with adjustable striker**
- **paumelle hinges**
- **pivot hinges**

OPENING:

- *hinged door - 180°*
- *walk-in closet door*
- *pivot sliding door*
- *external sliding door*
- *inner wall sliding door*

HEIGHT:

up to 2100 mm (nominal measurement)

Tratti distintivi *Distinctive traits*

Vivace con stipite su misura

È disponibile con
CERNIERA A POMELLA
(anche in tinta)
O A BILICO.

Entrambe permettono
un'**APERTURA A 180°.**

It is available with
PAUMELLE HINGE
(also in matching colour)
OR PIVOT HINGE.

Both allow a
180° OPENING.

Garantisce la **LINEARITÀ**
senza giunzioni, enfatizzando
l'armonia estetica dello stipite.

Guarantees **LINEARITY**
without joints, highlighting the
harmony of the jamb.

Scopri tutti i Plus delle Collezioni da pagina 275.
Discover all the Plus of the Collections from page 275.

Scopri la Collezione Vivace in alcuni dei nostri progetti ambientati.

Discover the Vivace Collection in some of our interior projects.



Cerniera a pomella
Paumelle hinge



Cerniera a bilico
Pivot hinge

COLLEZIONE
Vivace con stip. su m.

Dinamica

con stipite su misura

La vita odierna è movimento. Desideri e tendenze sono in evoluzione continua. Dinamica risponde adattandosi al vostro stile di vita con soluzioni estetiche attuali.

L'essenzialità delle linee è resa personalizzabile dalla scelta del coprifilo: inclinato, dritto, classico e barocco.

Today's life is on the go. Wishes and trends are continuously evolving. Dinamica adapts to your style of life with updated aesthetic qualities, combining passion for wood and a powerful design.

The essential lines can be custom-tailored by choosing one of the two types of casing: inclined, straight, classic and barocco.

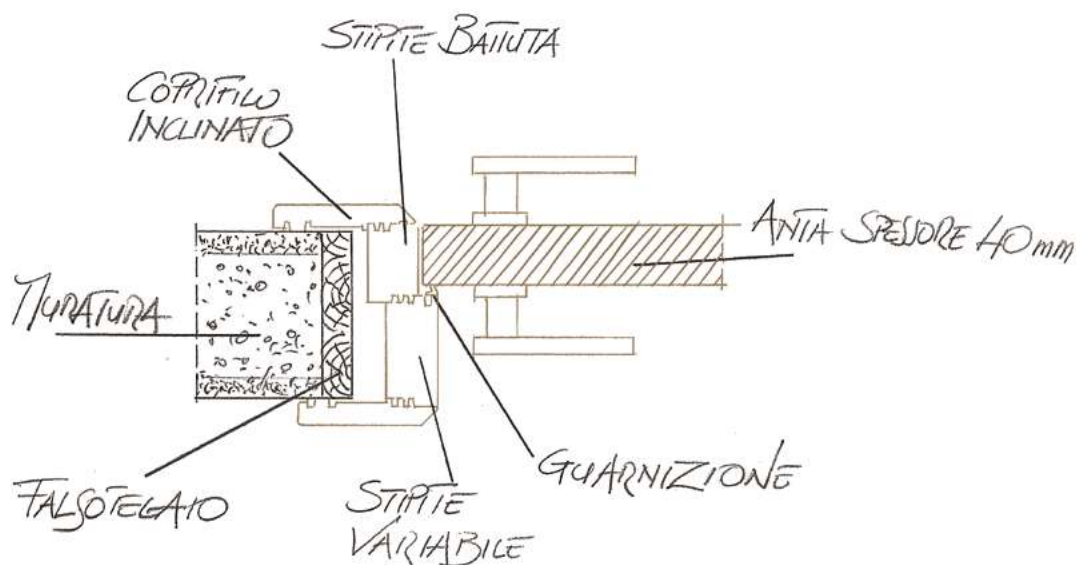

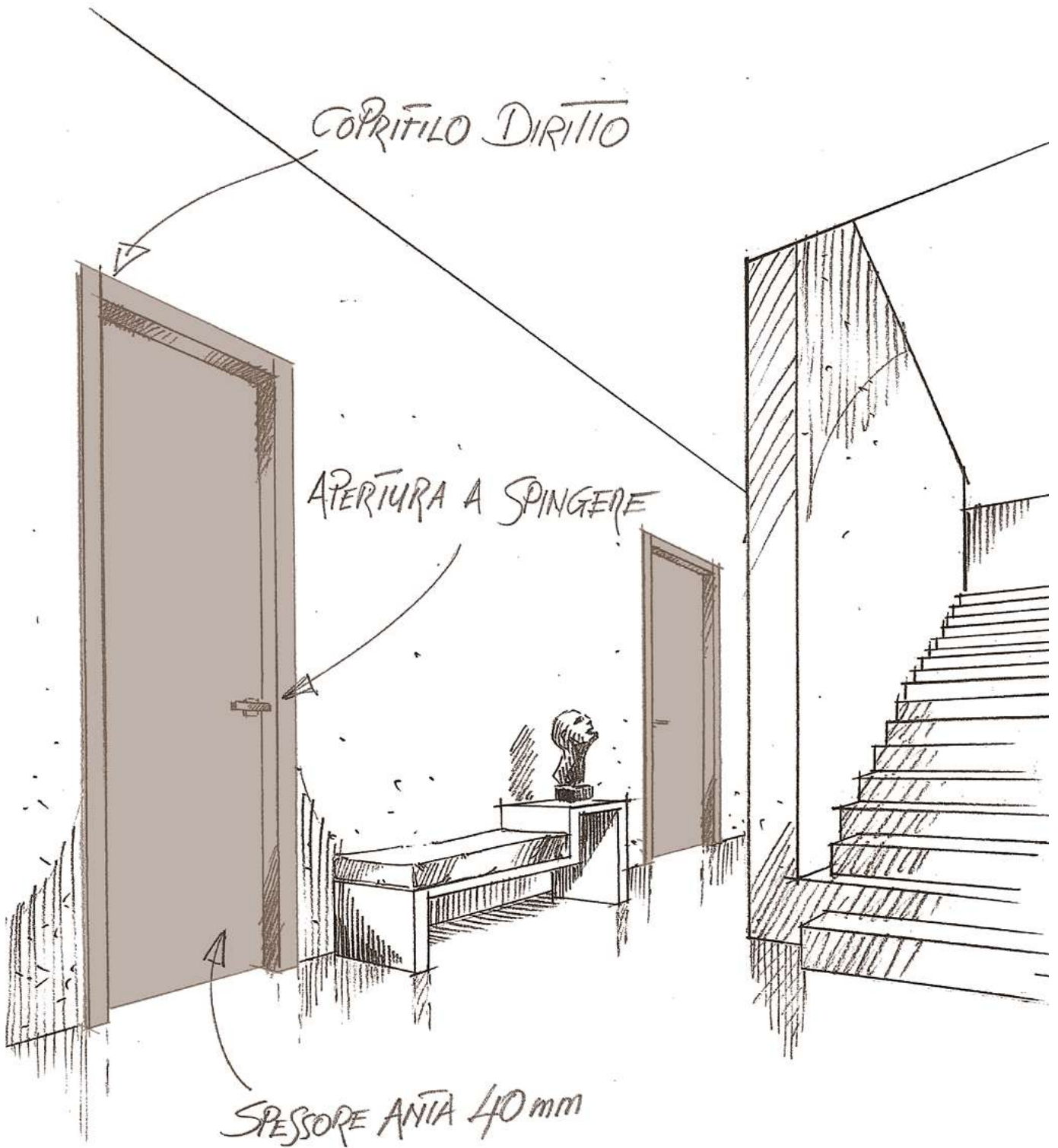

Caratteristiche/*Features* **Dinamica** con stipite su misura



CARATTERISTICHE:

- l'anta rientra leggermente rispetto al coprifiolo
- anta con telaio in legno di abete giuntato a pettine e stipite in listellare di abete
- incastro coprifiolo/stipite a pettine
- personalizzabile nelle misure

ANTA:

- spessore 40 mm
- 1 tirante di registrazione, lato maniglia
- anta rivestita sui 4 bordi

STIPITE:

- su misura fino a muri di 580 mm
- spessore 33 mm con battuta 12 mm
- guarnizione in 5 colori

COPRIFILO:

- multistrato di pioppo rivestito
- coprifiolo dritto con apertura 105° - di serie
- coprifiolo inclinato con apertura 135° - di serie
- coprifiolo classico con apertura 110° - optional
- coprifiolo barocco con apertura 110° - optional

ACCESSORI:

- serratura magnetica con incontro regolabile
- cerniere a scomparsa, registrabili su 3 assi
- cover dello stesso colore dell'anta - di serie
- kit accessori colore nero - optional

TIPOLOGIA DI APERTURA:

- porta battente
- cabina armadio
- porta a libro
- porta rototraslante
- scorrevole esterno muro
- scorrevole interno muro

ALTEZZA:

personalizzabile in altezza

FEATURES:

- the door comes in slightly in relation to the casing
- finger-jointed fir frame and spruce blockboard jamb
- finger-jointed jamb/cover
- customisable measurements

DOOR LEAF:

- thickness 40 mm
- 1 adjustable tie rod, handle side
- four-side edging

JAMB:

- customised jamb for non-standard walls till 580 mm
- 33 mm thick with 12 mm stop
- seal in 5 colours

CASING:

- multilayered poplar coated
- straight casing with 105° opening - standard equipment
- tilted casing with 135° opening - standard equipment
- classic casing with 110° opening - optional
- baroque casing with 110° opening - optional

ACCESSORIES:

- magnetic lock with adjustable striker
- concealed hinges, adjustable on 3 axes
- cover of the same color of the door leaf - standard equipment
- black accessories kit - optional

OPENING:

- hinged door
- walk-in closet door
- folding door
- pivot sliding door
- external sliding door
- inner wall sliding door

HEIGHT:

height customizable

Tratti distintivi *Distinctive traits*

Dinamica con stipite su misura

Permette di scegliere tra
4 DIVERSI COPRIFILI:
dritto, inclinato, classico, barocco.

It allows you to choose between
4 DIFFERENT CASINGS:
straight, tilted, classic, baroque.

Permette di avere l'anta estesa
FINO AL SOFFITTO
per un design che ne valorizza
l'impatto estetico.

Allows the leaf to be extended
UP TO THE CEILING
for a design that enhances the
aesthetic impact.

Scopri tutti i Plus delle Collezioni da pagina 275.
Discover all the Plus of the Collections from page 275.

Scopri la Collezione Dinamica in alcuni dei nostri progetti ambientati.

Discover the Dinamica Collection in some of our interior projects.



COLLEZIONE
Dinamica

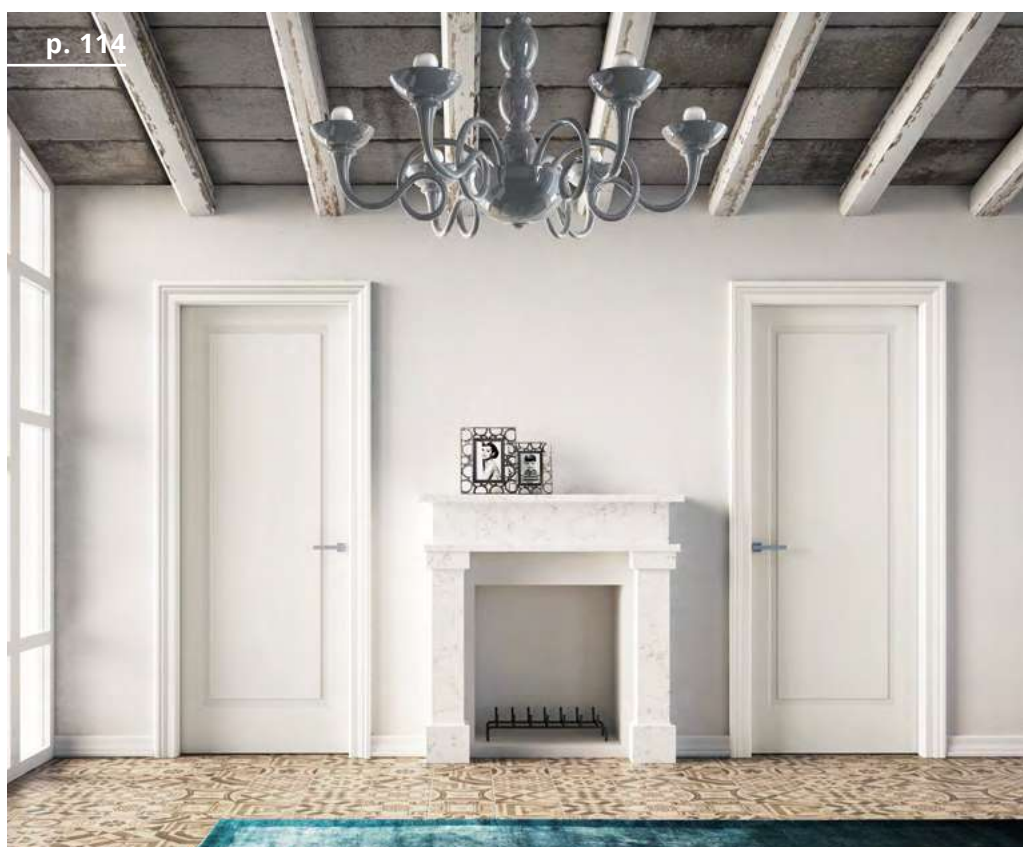

Unica

con stipite su misura

La collezione Unica conferisce pulizia ed essenzialità delle linee. Utilizzando l'innovativa cerniera a scomparsa registrabile si riesce a mantenere la complanarità e si elimina la giunzione tra stipite e coprifilo.

Il connubio di questi elementi ha reso indispensabile una specifica progettualità per la posa coperta da brevetto europeo.

The Unica collection provides clean and essential lines. The innovative adjustable hidden hinge allows you to maintain coplanarity and eliminate the junction between jamb and casing.

The combination of these elements includes a specific installation project, which is covered by European patent.

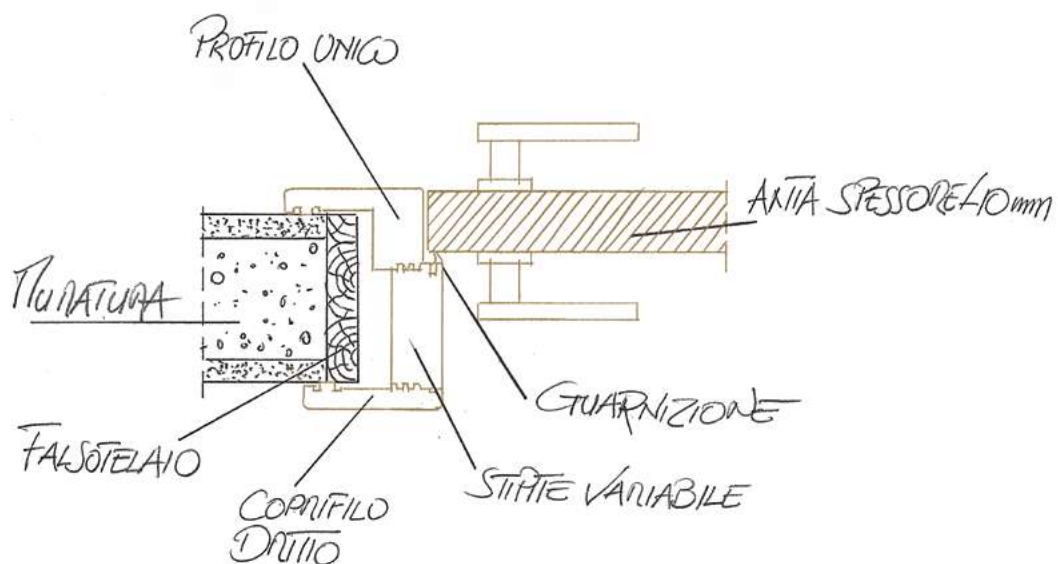



GALLERY

MANIGLIE SCAVATE

GUIDA

COLLEZIONE
Unica

PLUS

COMPLEMENTI

L'AZIENDA

Caratteristiche/*Features* **Unica** con stipite su misura



CARATTERISTICHE:

- complanarità anta-coprifilo sul lato interno stanza
- anta con telaio in legno di abete giuntato a pettine e stipite in listellare di abete
- personalizzabile nelle misure

ANTA:

- spessore 40 mm
- spessore 56 mm - optional
- 1 tirante di registrazione, lato maniglia (anta 40 mm)
- 2 tiranti di registrazione - optional (anta 56 mm)
- anta rivestita sui 4 bordi

STIPITE:

- su misura fino a muri di 580 mm
- spessore 33 mm con battuta 12 mm
- guarnizione in 5 colori

COPRIFILO:

- multistrato di pioppo rivestito

ACCESSORI:

- serratura magnetica con incontro regolabile
- cerniere a scomparsa, registrabili su 3 assi
- cover dello stesso colore dell'anta - di serie
- kit accessori colore nero - optional

TIPOLOGIA DI APERTURA:

- porta a battente
- cabina armadio
- porta a libro
- porta rototraslante
- scorrevole esterno muro
- scorrevole interno muro

ALTEZZA:

personalizzabile in altezza

FEATURES:

- coplanarity between door leaf and casing, inside the room
- finger-jointed fir frame and spruce blockboard jamb
- customizable measurements

DOOR LEAF:

- thickness 40 mm
- thickness 56 mm - optional
- 1 adjustable tie rod, handle side (40 mm door leaf)
- 2 adjustable tie rods - optional (56 mm door leaf)
- four-side edging

JAMB:

- customised jamb for non-standard walls till 580 mm
- 33 mm thick with 12 mm stop
- seal in 5 colours

CASING:

- multilayered poplar coated

ACCESSORIES:

- magnetic lock with adjustable striker
- concealed hinges, adjustable on 3 axes
- cover of the same color of the door leaf - standard equipment
- black accessories kit - optional

OPENING:

- hinged door
- walk-in closet door
- folding door
- pivot sliding door
- external sliding door
- inner wall sliding door

HEIGHT:

height customizable

Tratti distintivi *Distinctive traits*

Unica con stipite su misura

Grazie alle sue proprietà strutturali che includono un dispositivo di ancoraggio brevettato, Unica permette di avere contemporaneamente:

- CERNIERA A SCOMPARSA,
- APERTURA A 180°,
- COMPLANARITÀ TRA ANTA E COPRIFILO.

Thanks to its structural properties, which include a patented anchoring device, Unica makes it possible to have simultaneously:

- *HIDDEN HINGE,*
- *180° OPENING,*
- *COPLANARITY BETWEEN DOOR AND FRAME.*

Permette di scegliere tra
ANTA DA 56 mm
E DA 40 mm.

*Choose between
56 mm LEAF
AND 40 mm.*

Scopri tutti i Plus delle Collezioni da pagina 275.
Discover all the Plus of the Collections from page 275.

Scopri la Collezione Unica in alcuni dei nostri progetti ambientati.

Discover the Unica Collection in some of our interior projects.

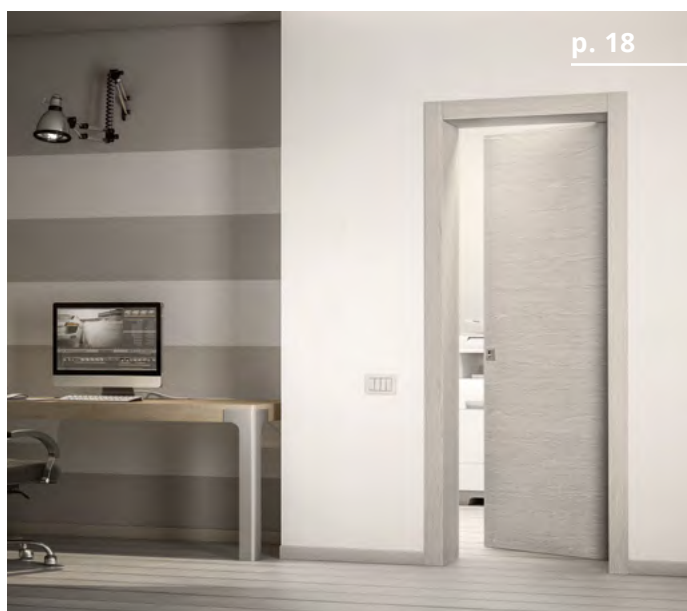
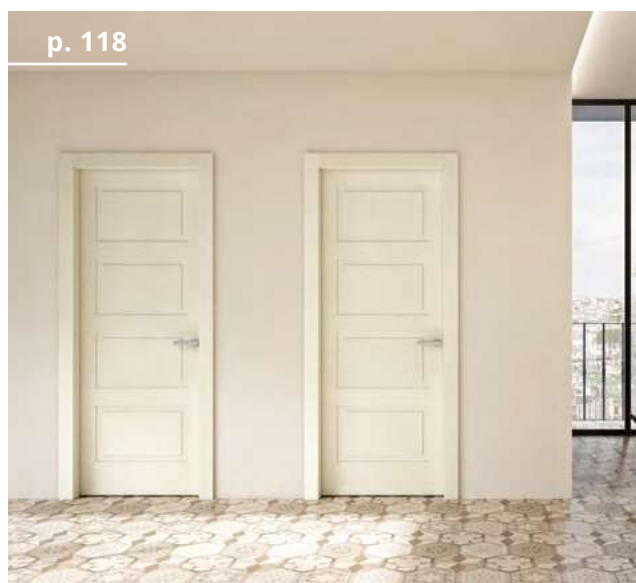
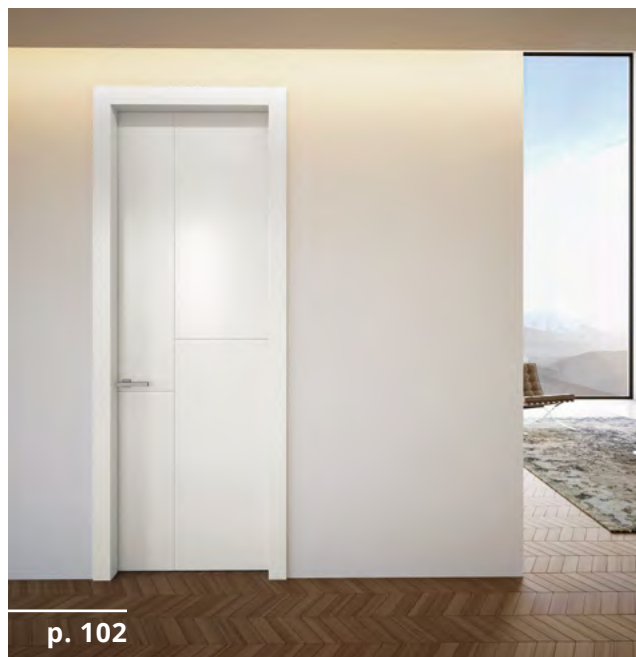

Inversa

con stipite su misura

CON INVERSA CAMBIA IL CONCETTO DI APERTURA

La particolarità di Inversa è la piena complanarità tra anta e coprifilo in vista esterno ambiente.

Per una piena continuità tra parete e porta è stato necessario capovolgere il concetto di apertura.

WITH INVERSA THE OPENING CONCEPT HAS CHANGED

The distinctive trait of Inversa is its perfect co-planarity between door leaf and casing, corridor side (priority view).

To get a complete continuity between the wall and the door, we had to overturn the opening concept.

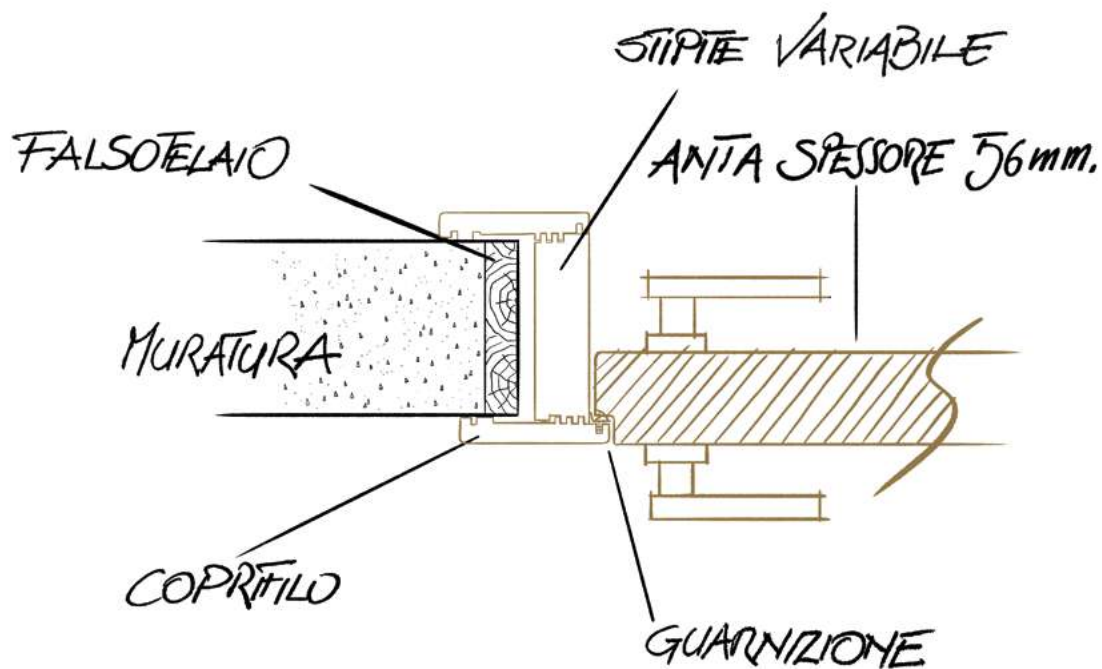

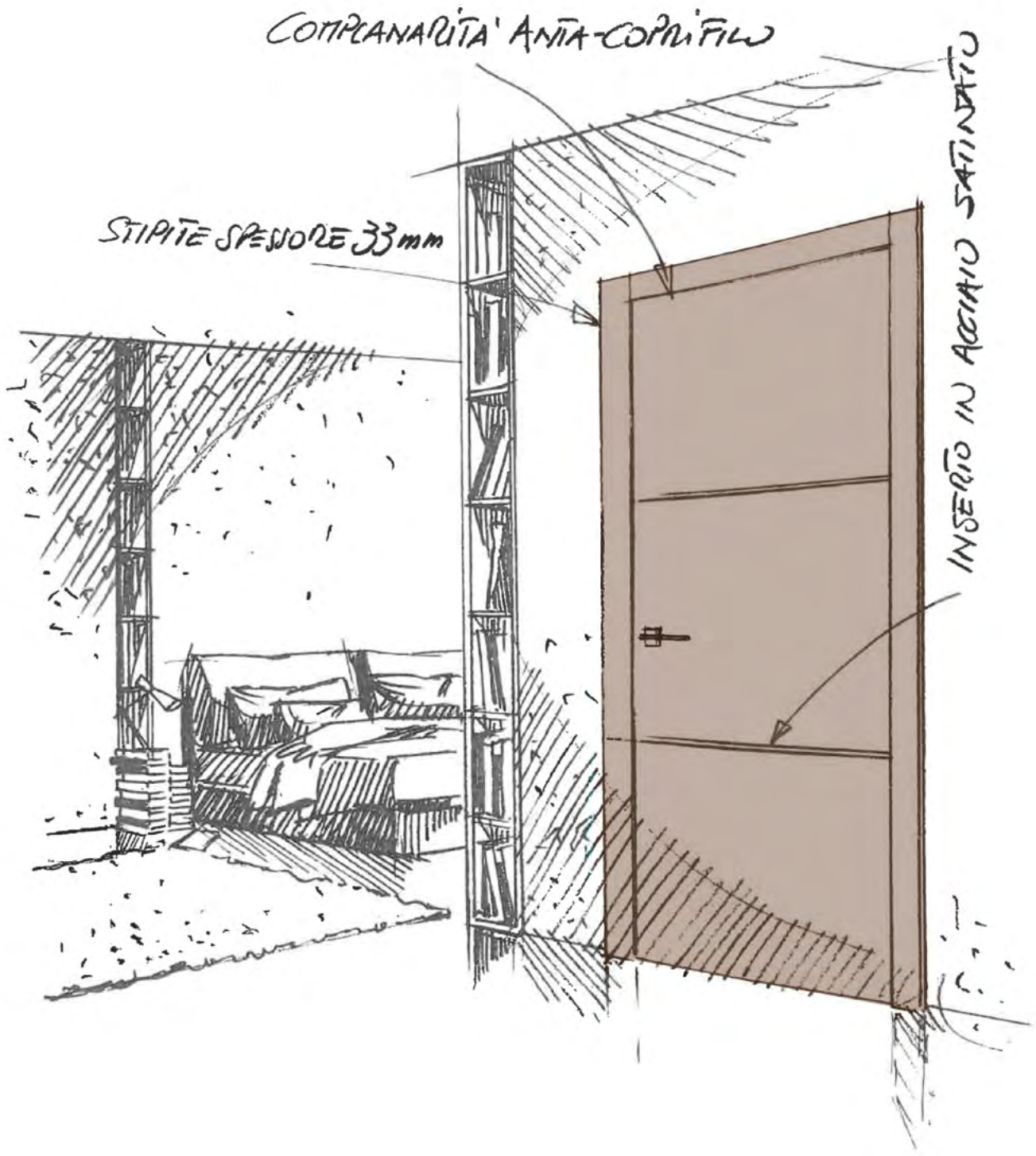

Caratteristiche/*Features*

Inversa

con stipite su misura



CARATTERISTICHE:

- complanarità anta-coprifilo, esterno stanza
- anta con telaio in legno di abete giuntato a pettine e stipite in listellare di abete
- personalizzabile nelle misure

N.B. Il punto di giunzione tra pavimenti diversi deve essere esterno stanza

ANTA:

- spessore 56 mm
- 2 tiranti di registrazione - optional
- anta rivestita sui 4 bordi

STIPITE:

- su misura fino a muri di 580 mm
- spessore 33 mm con battuta 12 mm
- guarnizione in 5 colori

COPRIFILO:

- multistrato di pioppo rivestito

ACCESSORI:

- serratura magnetica con incontro regolabile
- cerniere a scomparsa registrabili
- cover dello stesso colore dell'anta - di serie
- kit accessori colore nero - optional

TIPOLOGIA DI APERTURA:

- porta a battente

ALTEZZA:

personalizzabile in altezza

FEATURES:

- coplanarity between door leaf and casing, outside the room
- finger-jointed fir frame and spruce blockboard jamb
- customisable measurements

N.B. The junction point between different floors must be outside the room.

DOOR LEAF:

- thickness 56 mm
- 2 adjustable tie rods - optional
- four-side edging

JAMB:

- "15 mm pitch" customised jamb for non-standard walls till 580 mm
- 33 mm thick with 12 mm stop
- seal in 5 colours

CASING:

- multilayered poplar coated

ACCESSORIES:

- magnetic lock with adjustable striker
- concealed adjustable hinges
- cover of the same color of the door leaf - standard equipment
- black accessories kit - optional

OPENING:

- hinged door

HEIGHT:

height customizable

Tratti distintivi *Distinctive traits*

Inversa con stipite su misura

Permette la
COMPLANARITÀ
tra anta e coprifilo sul lato esterno
stanza con possibilità di scegliere
**SOLUZIONI A SPINGERE
O A TIRARE.**

*Allows the **COMPLANARITY**
between door and casing on the
outside of the room with the
possibility of choosing
PUSH OR PULL SOLUTIONS.*

Garantisce la **LINEARITÀ**
senza giunzioni, unita alla
possibilità di estendere l'anta
FINO AL SOFFITTO.

*It guarantees **LINEARITY**
jointless, combined with the
possibility of extending the leaf up
TO THE CEILING.*

Scopri tutti i Plus delle Collezioni da pagina 275.
Discover all the Plus of the Collections from page 275.

Scopri la Collezione Inversa in alcuni dei nostri progetti ambientati.

Discover the Inversa Collection in some of our interior projects.



Leggera

Priva di stipite e coprifilo, Leggera ha uno stile minimale, perfetto per ambienti molto lineari e moderni. A parete si vede, e quindi si esalta, solo il design puro della porta.

Leggera riesce anche a "mimetizzarsi" con la parete di fondo, creando un effetto di estrema pulizia di linee.

Viene proposta in entrambe le soluzioni di apertura: A SPINGERE E A TIRARE.

No jambs and casings, Leggera has a minimal style, perfect for linear and modern settings. Therefore, Leggera can "blend in with" the background wall, creating an exceptional clean look.

It is available in BOTH PUSH AND PULL OPENING OPTIONS.

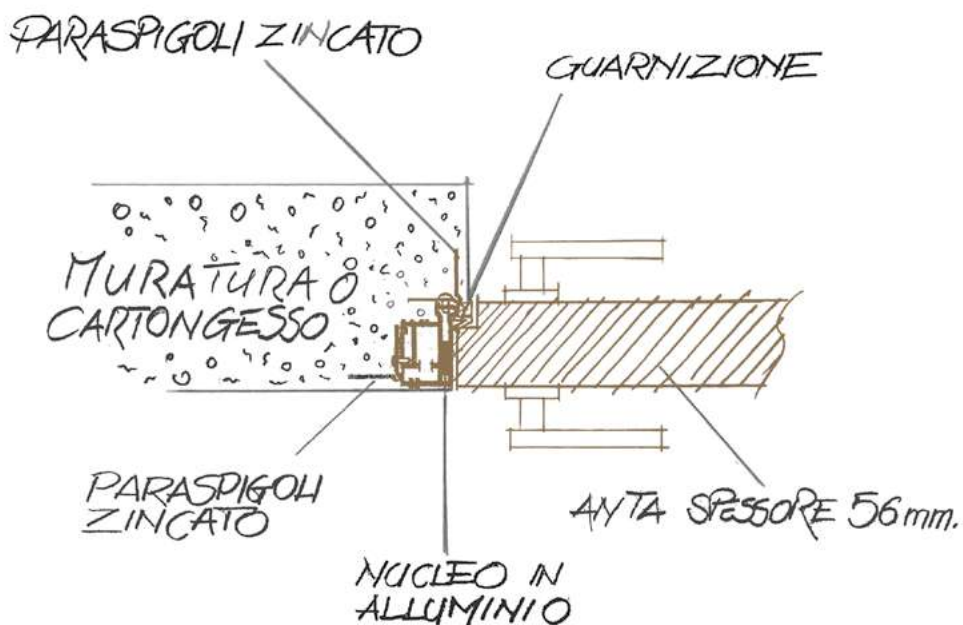

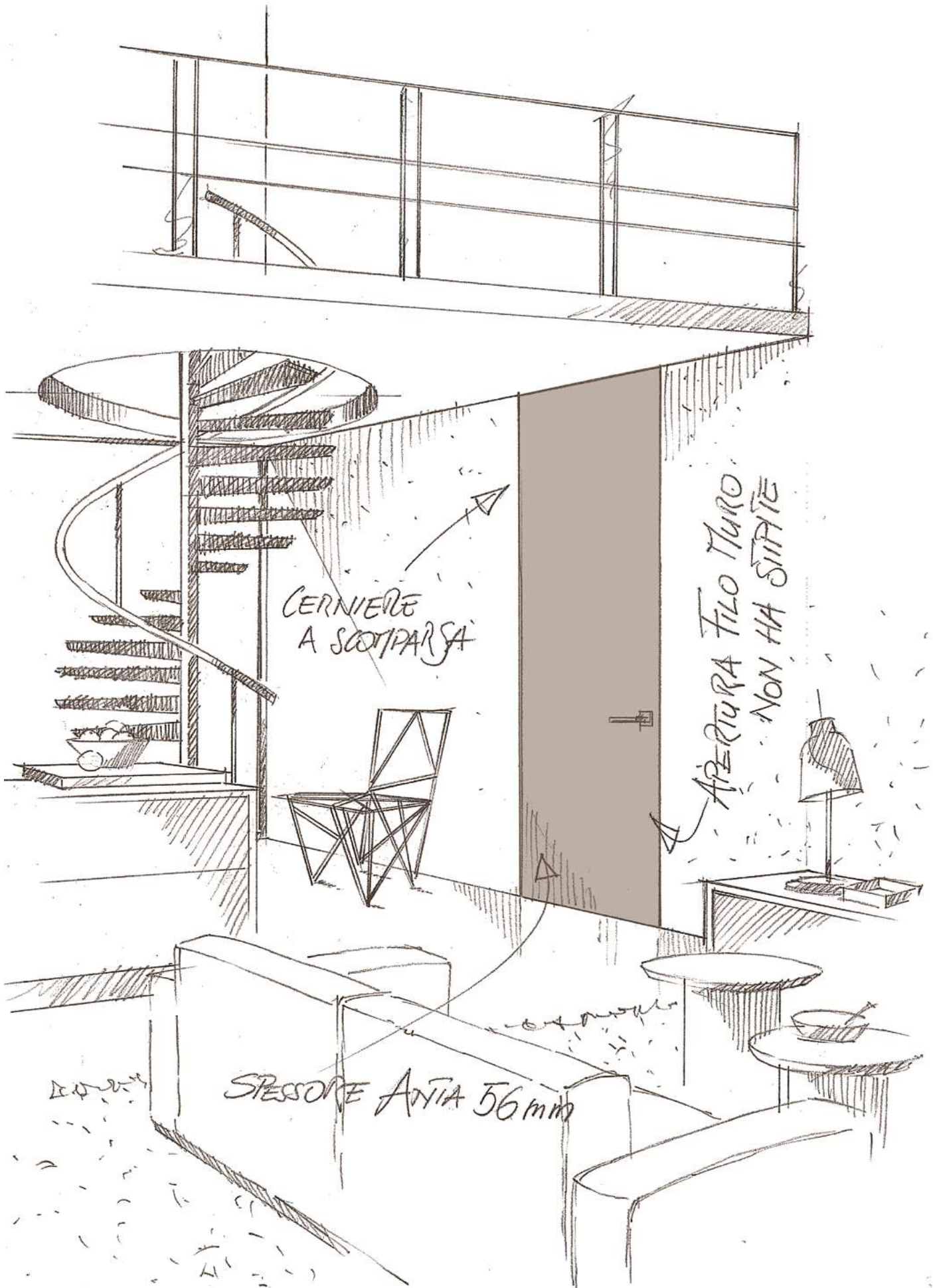

GALLERY

MANIGLIE SCAVATE

GUIDA

COLLEZIONE
Leggera

PLUS

COMPLEMENTI

L'AZIENDA

Caratteristiche/*Features* Leggera



CARATTERISTICHE:

- complanarità anta filo muro, esterno stanza
- non ha stipite, ha un nucleo in alluminio estruso unico per muratura o cartongesso, brevetto Pivato
- personalizzabile nelle misure

N.B. Il punto di giunzione tra pavimenti diversi deve essere esterno stanza

ANTA:

- anta in legno di abete giuntato a pettine rivestita
- spessore 40 mm
- spessore 56 mm - optional
- 1 tirante di registrazione, lato maniglia (anta 40 mm)
- 2 tiranti di registrazione - optional (anta 56 mm)
- anta rivestita sui 4 bordi

L'anta può essere tinteggiata o rivestita come la parete.

NUCLEO:

- profilo rigido grazie alle anime di spessore di circa 2 mm, questo deve essere posato contestualmente alle pareti
- disponibile in alluminio verniciabile o bianco
- OPTIONAL - predisposizione battiscopa a filo muro
- personalizzabile nelle misure adatto a qualsiasi spessore muro

ACCESSORI:

- serratura magnetica con incontro regolabile
- cerniere a scomparsa, registrabili su 3 assi
- cover in grigio alluminio di serie
- kit accessori colore nero - optional

TIPOLOGIA DI APERTURA:

- porta battente
 - 90° - a spingere
 - 180° - a tirare

ALTEZZA:

fino al soffitto H 3000 mm previa verifica fattibilità modello / finitura / dimensioni

FEATURES:

- coplanarity between door leaf and casing, outside the room
- jamb-free, unique extruded aluminium core for brick or dry wall, Pivato patented
- customisable measurements

N.B. The junction point between different floors must be outside the room.

DOOR LEAF:

- finger-jointed fir wood door and jamb finger-jointed wood clad
- 40 mm thick
- 56 mm thick - optional
- 1 adjustable tie rod - handle side (40 mm door leaf)
- 2 adjustable tie rods - optional (56 mm door leaf)
- four-side edging

The leaf can be painted or lined to match the wall.

CORE:

- rigid profile thanks to 2 mm wide cores, it must be intalled simultaneously with the walls
- available in varnished aluminium or white
- OPTIONAL - preparation of baseboard flush with the wall
- customisable measures, fits any wall thickness

ACCESSORIES:

- magnetic lock with adjustable striker
- concealed hinges, adjustable on 3 axes
- aluminum gray cover - standard equipment
- black accessories kit - optional

OPENING:

- hinged door
 - 90° - to push
 - 180° - to pull

HEIGHT:

up to 3000 mm height - subject to verification of feasibility about model / finish / dimensions

Tratti distintivi *Distinctive traits*

Leggera

È la **FILOMURO**
della gamma Pivato.

Il **NUCLEO A SCOMPARSA**
garantisce la perfetta linearità
tra l'anta e il muro.

*This is the **FLUSH-TO-WALL
DOOR** in the Pivato range.*

*The **CONCEALED CORE**
guarantee perfect linearity
between the door and the wall.*

Si presta a una grande
PERSONALIZZAZIONE:
può essere tinteggiata o rivestita
con carta da parati per emergere
o "mimetizzarsi" con la parete.

L'anta può estendersi
FINO AL SOFFITTO.

*It can be highly **PERSONALISED:**
it can be painted or covered with
wallpaper to stand out or "blend
in" with the wall.*

*The door can be extended up
TO THE CEILING.*

Scopri tutti i Plus delle Collezioni da pagina 275.

Discover all the Plus of the Collections from page 275.

Scopri la Collezione Leggera in alcuni dei nostri progetti ambientati.

Discover the Leggera Collection in some of our interior projects.



Scorrevoli Special

Le **Scorrevoli Special** di Pivato ti danno la possibilità di scegliere tra varie soluzioni di scorrimento e regalano la sensazione di avere in casa una parete in movimento.

Non una semplice porta, ma un elemento d'arredo dalle molteplici soluzioni di apertura per individuare quella che più si adatta all'ambiente.

The Pivato "Special Sliding doors" give you the possibility to choose between various sliding solutions and they give you the illusion of having a moving wall at home.

Not a simple door, but a piece of furniture with alternative opening solutions to identify the one that best suits the environment.

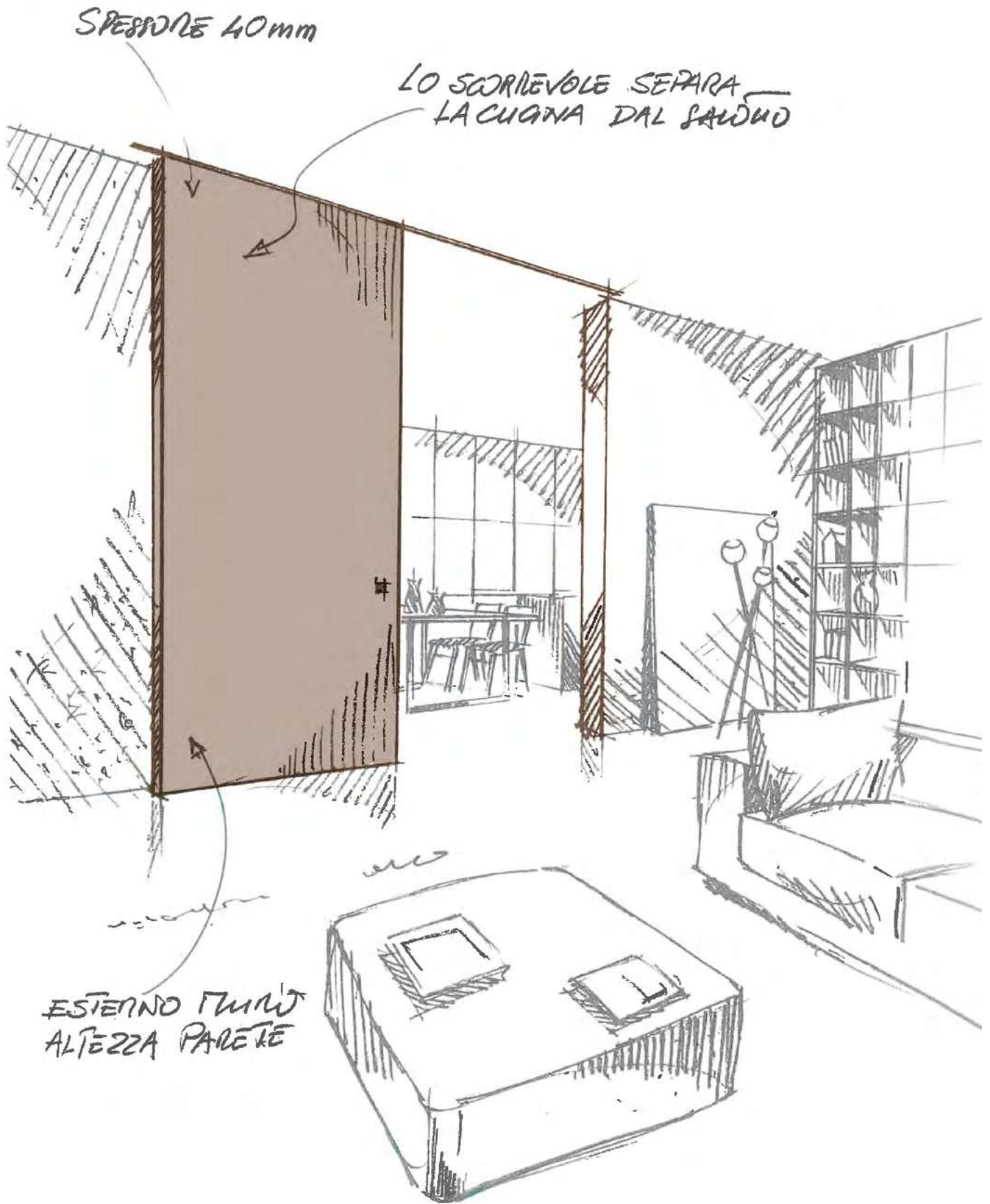

Caratteristiche / *Features* Scorrevoli Special



CARATTERISTICHE DEI SISTEMI DI SCORRIMENTO:

- Minimal Soft Pro
- Alchemy
- Feeling
- Linear20
- Basic
- Light

ANTA:

- anta in legno di abete giuntato a pettine rivestita in legno
- spessore 40 mm
- 1 tirante di registrazione, lato placca
- anta rivestita sui 4 bordi

ALTEZZA:

fino a 3000 mm previa verifica fattibilità modello / finitura / dimensioni

SLIDING SYSTEMS FEATURES:

- *Minimal Soft Pro*
- *Alchemy*
- *Feeling*
- *Linear20*
- *Basic*
- *Light*

DOOR LEAF:

- *inger-jointed fir wood door and jamb finger-jointed wood clad*
- *thickness 40 mm*
- *1 adjustable tie rod, plate side*
- *four-side edging*

HEIGHT:

up to 3000 mm - subject to verification of feasibility about model / finish / dimensions

GALLERY

MANIGLIE SCAVATE

GUIDA

COLLEZIONE
Scorrevoli Special

PLUS

COMPLEMENTI

L'AZIENDA

MINIMAL SOFT PRO

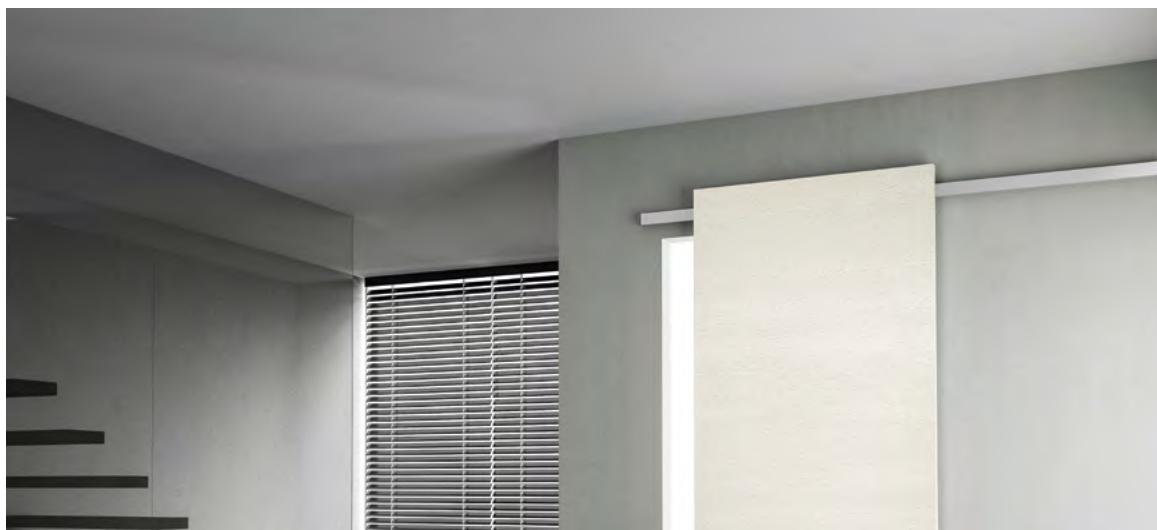

ALCHEMY

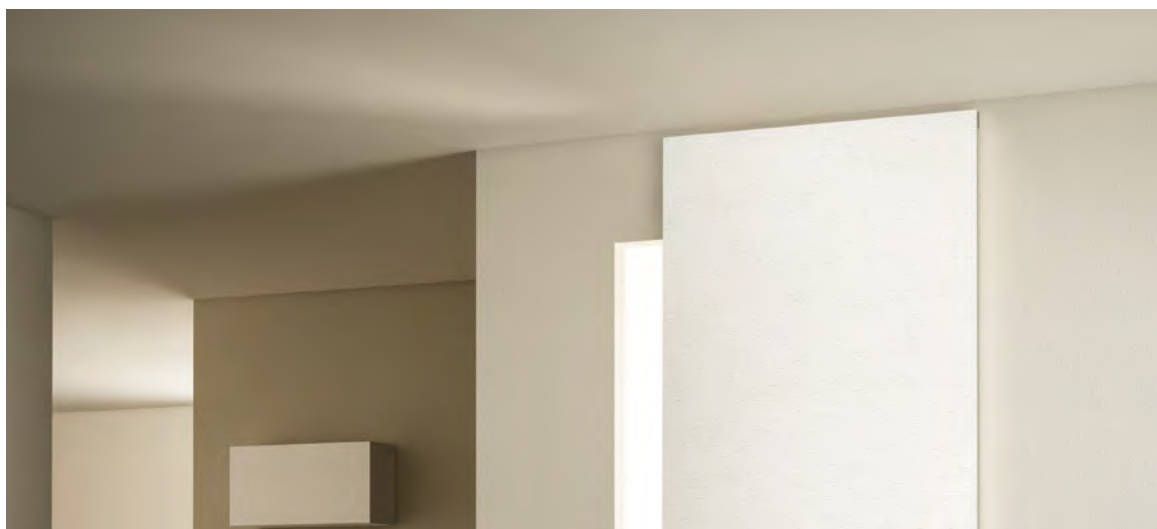

FEELING



LINEAR20

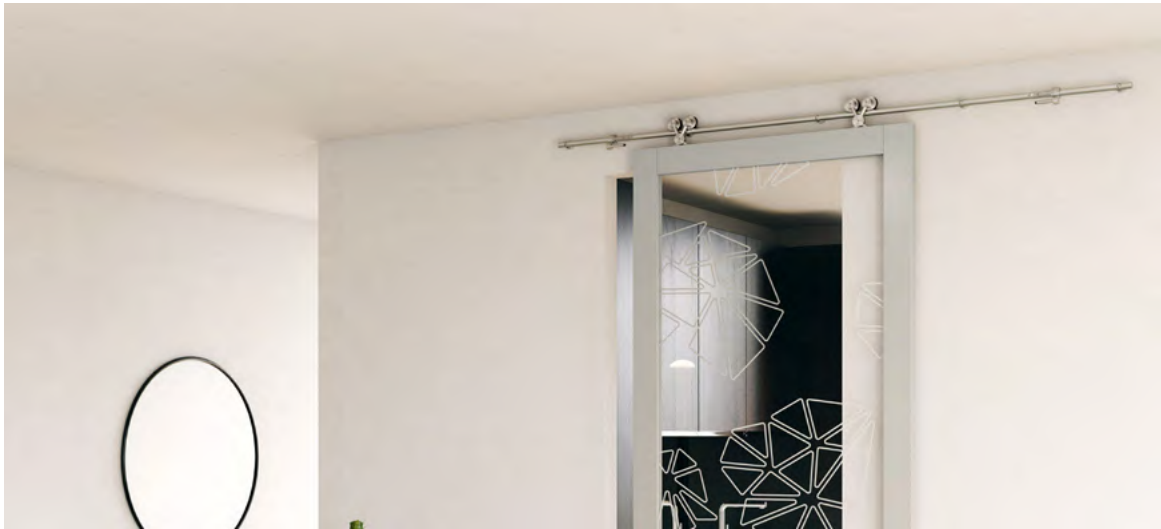

BASIC



LIGHT

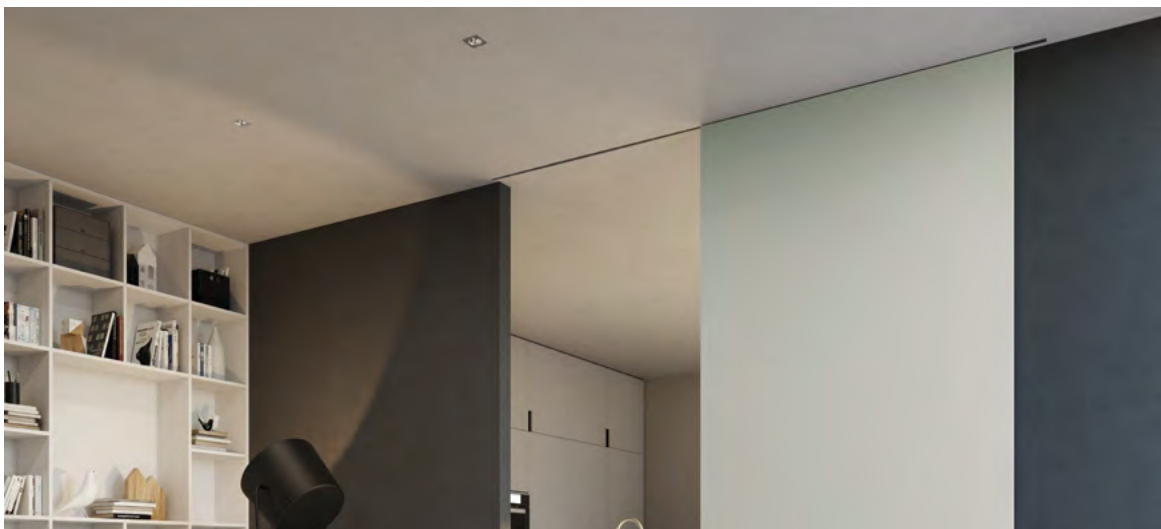

GALLERY

MANIGLIE SCAVATE

GUIDA

COLLEZIONE
Scorrevoli Special

PLUS

COMPLEMENTI

L'AZIENDA

Minimal Soft Pro





Sistema di scorrimento con apertura e chiusura frenante ad aria per una impareggiabile sensazione di morbidezza.

Sliding system with air braking opening/ closing system for an incomparable feeling of softness.



Alchemy





Il sistema senza binario a vista, nel quale l'anta scorre magicamente e fluidamente, dando l'illusione di una parete in movimento.

The system without surface rail, in which the leaf slides magically and fluidly, gives the impression of a moving wall.



Feeling





Il sistema di scorrimento con una forte personalità e un design essenziale dove ruote e anta si muovono in completa armonia.

The wheels and leaf of the sliding system, characterised by a strong personality and essential design, move in complete harmony.



Linear20





Il nuovo binario Linear20 migliora la solidità della porta grazie all'aggiunta di un terzo elemento circolare di sostegno che mantiene la struttura armoniosa anche dal punto di vista estetico.

Linear20 improves the solidity of the door by adding a third circular support element that keeps the structure aesthetically pleasing.



Basic





Il binario standard dallo stile rinnovato per conferirgli una grande personalità.

The renovated style of the standard rail provides great personality.



Light





Per chi ricerca la totale pulizia formale dove appare solo ciò che separa e divide, Pivato propone Light, ovvero la soluzione con il sistema di scorrimento completamente incassato a soffitto dove l'anta diventa la sola e indiscussa protagonista.

For those looking for dramatically clean lines that only reveal what separates and divides, Pivato proposes Light, the solution with the fully hidden sliding system where the door becomes the only and undisputed protagonist.



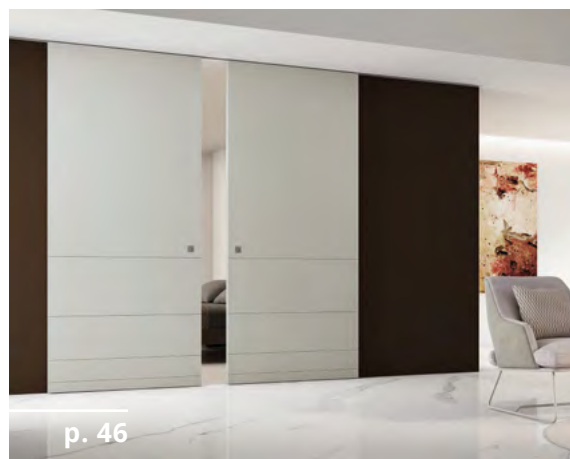



p. 74

Scopri la Collezione Scorrevoli Special in alcuni dei nostri progetti ambientati.

Discover the Scorrevoli Special Collection in some of our interior projects.

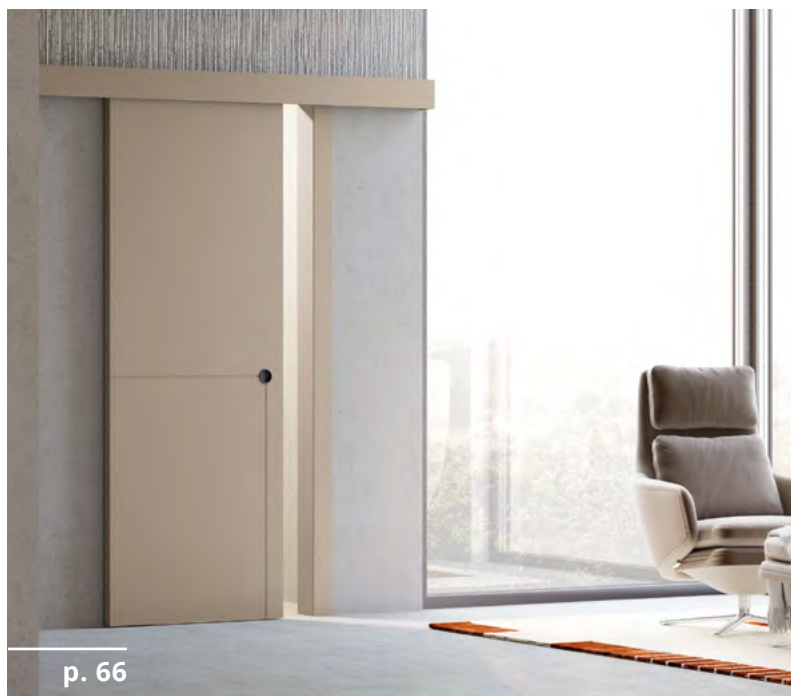

p. 66



p. 267



p. 30

Plus delle porte Pivato

Plus of Pivato's doors

- 01 Abete della Val di Fiemme / *Val di Fiemme fir* p. 276
- 02 Spessore anta 40 mm / *Door thickness 40 mm* p. 278
- 03 Spessore anta 56 mm / *Door thickness 56 mm* p. 278
- 04 Serratura e incontro regolabile con magnete / *Magnet lock and adjustable striker* p. 279
- 05 Anta rivestita sui 4 bordi / *Four-side edging* p. 280
- 06 Coprifilo telescopico / *Telescopic casing* p. 282
- 07 Stipite su misura / *Custom-made jamb* p. 283
- 08 Stipite reversibile / *Reversible jamb* p. 284
- 09 A filo sul lato esterno stanza / *Perfectly flush on the outside room* p. 286
- 10 Apertura a spingere e a tirare / *Push and pull opening* p. 287
- 11 Cerniera a scomparsa registrabile / *Adjustable concealed hinge* p. 288
- 12 Cerniera a bilico invisibile registrabile / *Adjustable invisible pivot hinge* p. 289
- 13 Serratura e incontro per scorrevoli / *Lock and striker for sliding doors* p. 290
- 14 Funzionalità tiranti / *Tie rod functionality* p. 291
- 15 Cerniera a pomella con apertura a 180° / *Paumelle hinge with 180° opening* p. 292
- 16 Cerniera a bilico registrabile con apertura 180° / *Adjustable pivot hinge with 180° opening* p. 292
- 17 Varietà del coprifilo / *Variety of casing options* p. 293
- 18 Profilo Ghost: 8 vantaggi / *Ghost profile: 8 advantages* p. 294
- 19 Brevetto industriale europeo dispositivo di ancoraggio / *European industrial patent anchoring device* p. 296
- 20 Filomuro con nucleo a scomparsa / *Flush-to-wall door with concealed core* p. 298

01 ABETE DELLA VAL DI FIEMME / VAL DI FIEMME FIR

PRESENTE NELLE
COLLEZIONI:

- Vivace con stipite su misura e coprifilo telescopico
- Opera50
- Vivace con stipite su misura

- Dinamica
- Unica
- Inversa
- Leggera
- Scorrevoli Special

Legno d'abete a crescita lenta,
garantisce qualità strutturali nel tempo.

*Slow-growing fir, guarantees structural
qualities over time.*

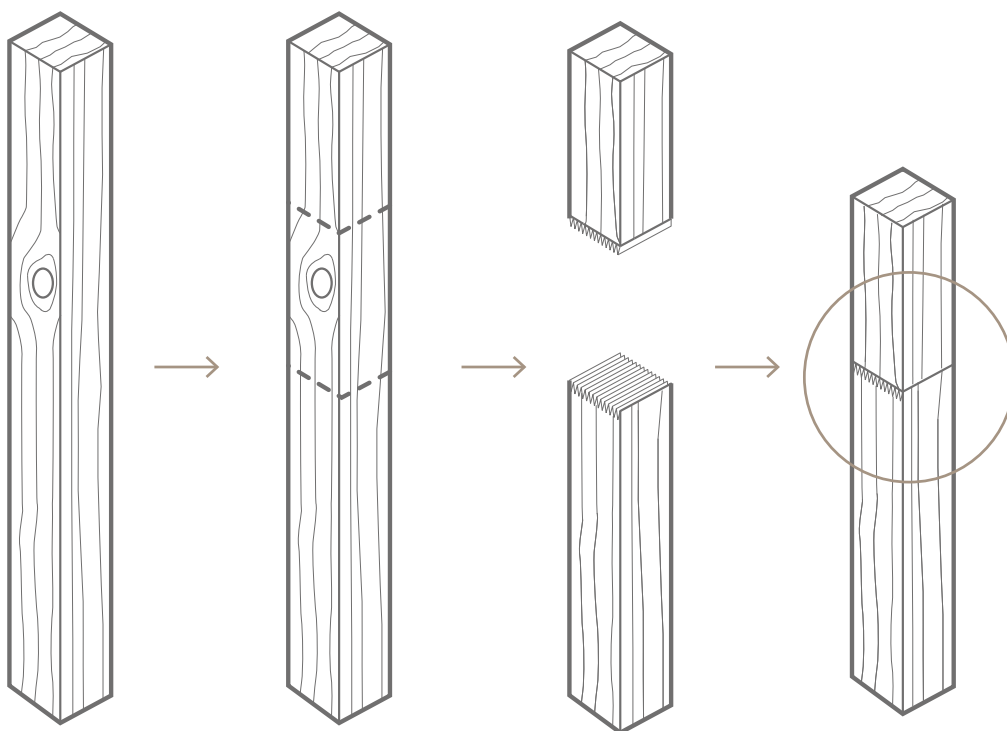

GIUNZIONE A PETTINE / FINGER JOINT

Usiamo pezzi di legno più corti,
senza nodi per renderlo più stabile.

*We use shorter wooden pieces,
no knots to make it more durable.*



LISTELLARE DI ABETE / FIR BLOCKBOARD

Una porta Pivato vince anche la prova più dura. La struttura in abete di una porta immersa nell'acqua per 24 ore si gonfia di meno di 1 millimetro.

A Pivato door also wins the toughest test. The spruce structure of a door, immersed in water for 24 hours, swells less than 1 millimeter.

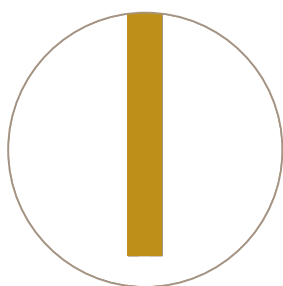

24 H

aumento spessore
thickening
+ 1 mm



MDF / MEDIUM-DENSITY FIBREBOARD

Una struttura in MDF dopo 24 ore di immersione nell'acqua si gonfia di oltre 5 mm: la porta non funziona più.

A MDF structure immersed in water for 24 hours swells more than 5 mm: the door no longer works.



24 H

aumento spessore
thickening
+ 5 mm



02 SPESSORE ANTA 40 mm / DOOR THICKNESS 40 mm

PRESENTE NELLE
COLLEZIONI:

- Vivace con stipite su misura e coprifilo telescopico
- Vivace con stipite su misura

- Dinamica
- Unica
- Leggera
- Scorrevoli Special

L'anta è realizzata in legno di abete giuntato a pettine.

The door leaf is made of finger joint fir wood.

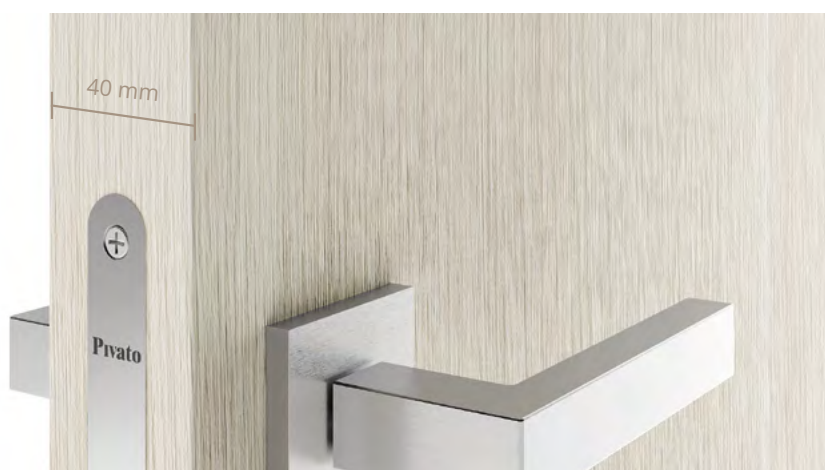

03 SPESSORE ANTA 56 mm / DOOR THICKNESS 56 mm

PRESENTE NELLE
COLLEZIONI:

- Opera50
- Unica

- Inversa
- Leggera

L'anta è realizzata in legno di abete giuntato a pettine.

The door leaf is made of finger joint fir wood.

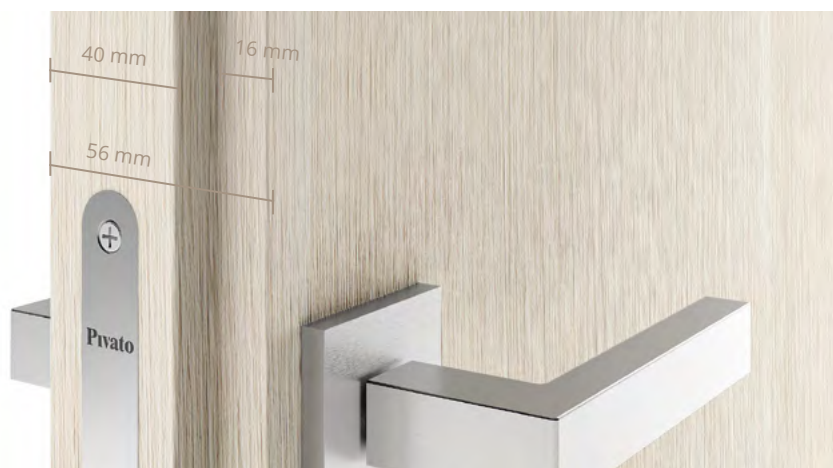

04 SERRATURA E INCONTRO REGOLABILE CON MAGNETE / MAGNET LOCK AND ADJUSTABLE STRIKER

PRESENTE NELLE
COLLEZIONI:

- Vivace con stipite su misura e coprifilo telescopico
- Opera50
- Vivace con stipite su misura
- Dinamica
- Unica
- Inversa
- Leggera

L'incontro regolabile accoglie la serratura permettendo una chiusura magnetica.

The adjustable striker welcomes the lock guaranteeing a perfect magnetic closure.



La chiusura fra anta e stipite avviene perchè
NELL'INCONTRO È
INSERITO UN MAGNETE.

*The closure between the door leaf and the jamb operates because there is a
MAGNET INTO THE
STRIKER.*

Colori cover disponibili:
Available cover finishes:



grigio satinato /
chrome grey



nero /
black



Per altre finiture, consultare il listino.
For other finishes, see price list.

05 ANTA RIVESTITA SUI 4 BORDI / FOUR-SIDE EDGING

PRESENTE NELLE
COLLEZIONI:

- Vivace con stipite su misura e coprifilo telescopico
- Opera50
- Vivace con stipite su misura

- Dinamica
- Unica
- Inversa
- Leggera
- Scorrevoli Special

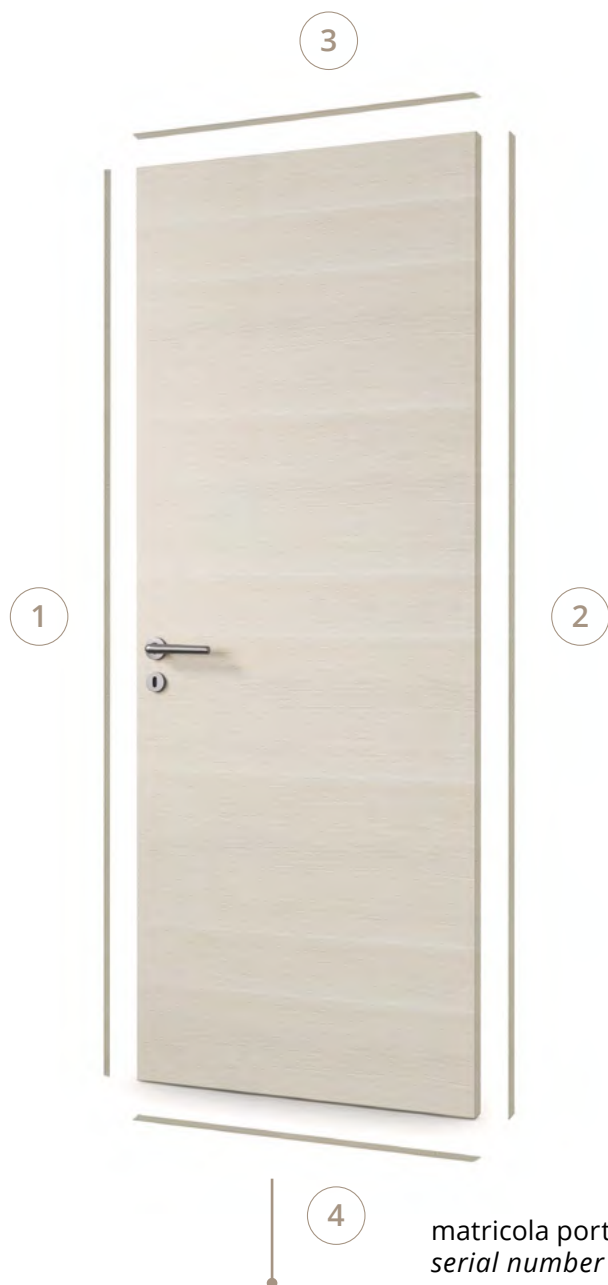

Grazie alla bordatura viene garantito un importante aspetto formale e funzionale: la perfetta continuità tra le due facciate dell'anta e i bordi.

Thanks to the edging it is guaranteed an important aspect: the perfect continuity between the two sides of the door and the edges.

matricola porta /
serial number

808 x 2100
CER F134

COLLEZIONE VIVACE
MOD. 0122 LISCIO
SPE:40

160203717.30

880 x 2140
CERNIERA A BILICO

SER F079
PB1A

**ROVERE GRIGIO SPAZZOLATO
DX**

SERRATURA MAGNETICA C/CH





Pivato adotta un bordo da 1 mm di spessore, tre volte superiore allo standard del mercato.

Questa caratteristica garantisce tre vantaggi:

- permette di raggiungere lo spigolo
- maggiore resistenza agli urti
- maggiore resistenza nel tempo

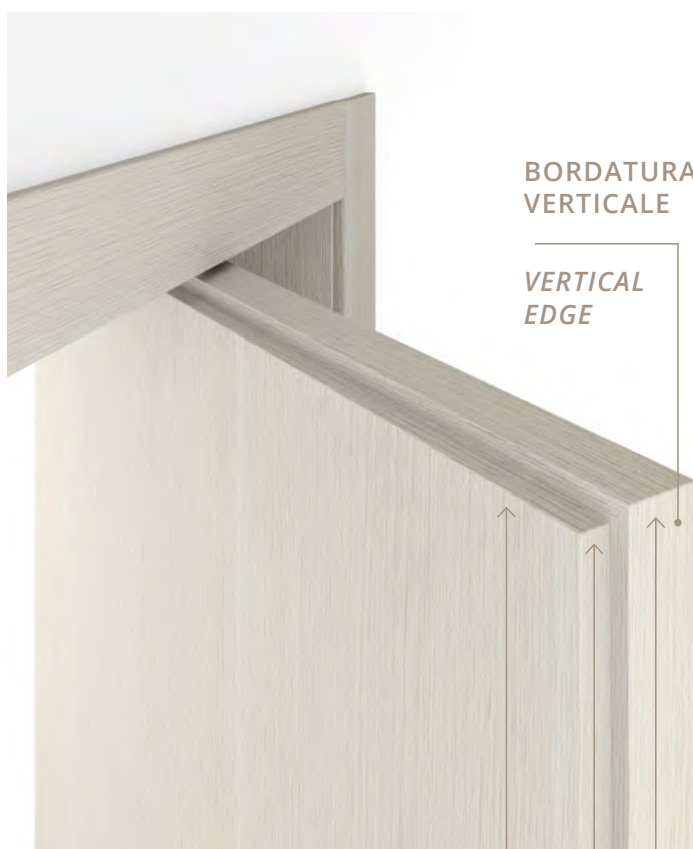

Pivato adopts a 1mm edge, three times thicker than the standard edges on the market.

This feature guarantees three advantages:

- *allows to radiate the corner*
- *greater resistance to impact*
- *greater resistance over time*



Bordatura
Edging

La bordatura può variare per alcune finiture.
The edging may vary for some finishes.

06 COPRIFILO TELESCOPICO / TELESCOPIC CASING

PRESENTE NELLE
COLLEZIONI:

- Vivace con stipite su misura e coprifiло telescopico
- Opera50

Il coprifiло telescopico ti permette di avere una porta che si adatta perfettamente anche a diverse misure di spessore del muro, assicurando comunque la coplanarità tra coprifiло ed anta, che è la prerogativa che caratterizza tutte le porte Pivato.

Grazie allo stipite passo 15 mm, studiato apposta per adattarsi ad ogni muro, coplanarità, pulizia ed estetica sono garantiti senza dover operare allargamenti alla parete.

The telescopic casing allows you to have a door that fits perfectly even to different wall thickness measurements, while still ensuring the coplanarity between the casing and door leaf, which is the prerogative that characterizes all Pivato doors.

Thanks to the 15 mm jamb, designed specifically to adapt to any wall, coplanarity, cleanliness and aesthetics are guaranteed without having to widen the wall.

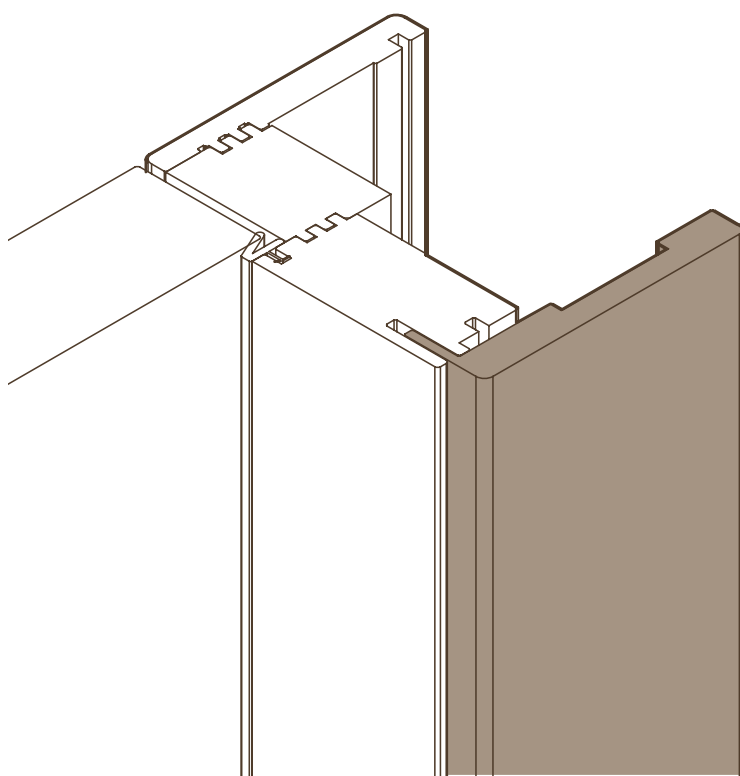

Coprifiло telescopico
Telescopic casing

Nell'esempio: Vivace con stipite su misura e coprifiло telescopico.

In the sample image: Vivace with custom-made jamb and telescopic casing.

07 STIPITE SU MISURA / CUSTOM-MADE JAMB

PRESENTE NELLE
COLLEZIONI:

- Vivace con stipite su misura e coprifilo telescopico
- Opera50
- Vivace con stipite su misura

- Dinamica
- Unica
- Inversa



Lo stipite su misura è studiato appositamente per adattarsi fino a muri di 580 mm. Coplanarità, pulizia ed estetica sono garantiti.



The custom-made jamb is studied specially for fit up to walls in 580 mm. Coplanarity, cleaning and aesthetics are guaranteed.

08 STIPITE REVERSIBILE / REVERSIBLE JAMB

PRESENTE NELLE
COLLEZIONI:

- Vivace con stipite su misura e coprifilo telescopico
- Opera50 (solo a spingere)

Cambiare il senso di apertura della tua porta non è mai stato così semplice.

Reversible jamb allows you to simply change the opening way of your door.

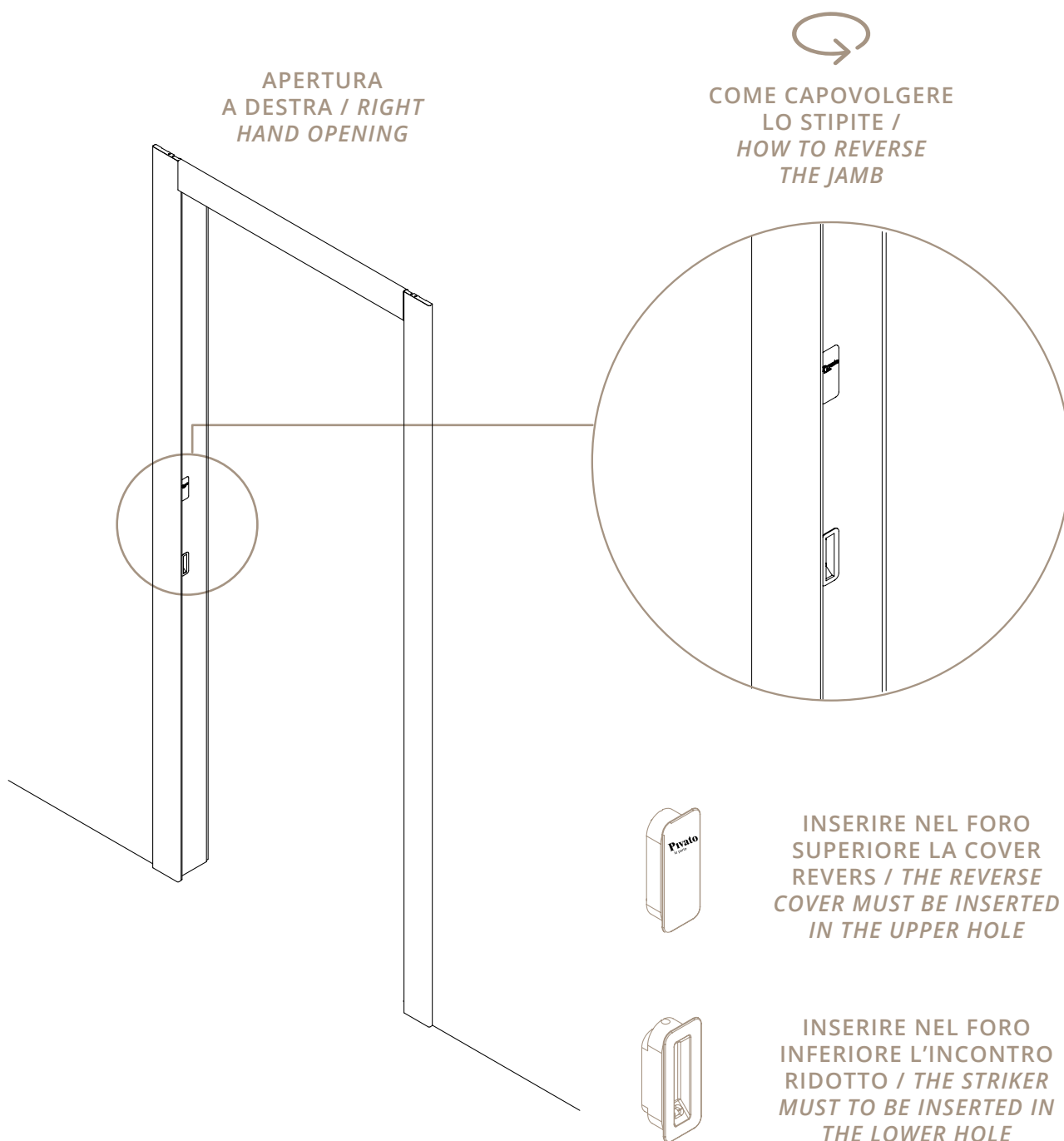

L'anta reversibile permette, in fase di posa in cantiere, di decidere il verso di apertura della porta.

The reversible leaf allows you to decide the opening way of the door during on site laying phase.

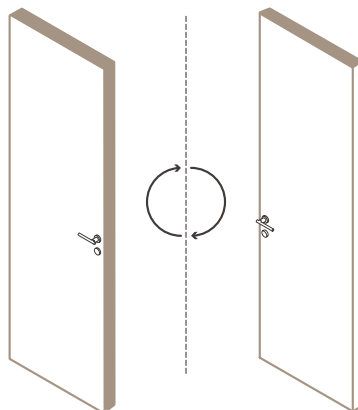

APERTURA
A SINISTRA / LEFT
HAND OPENING



COME CAPOVOLGERE
LO STIPITE /
HOW TO REVERSE
THE JAMB

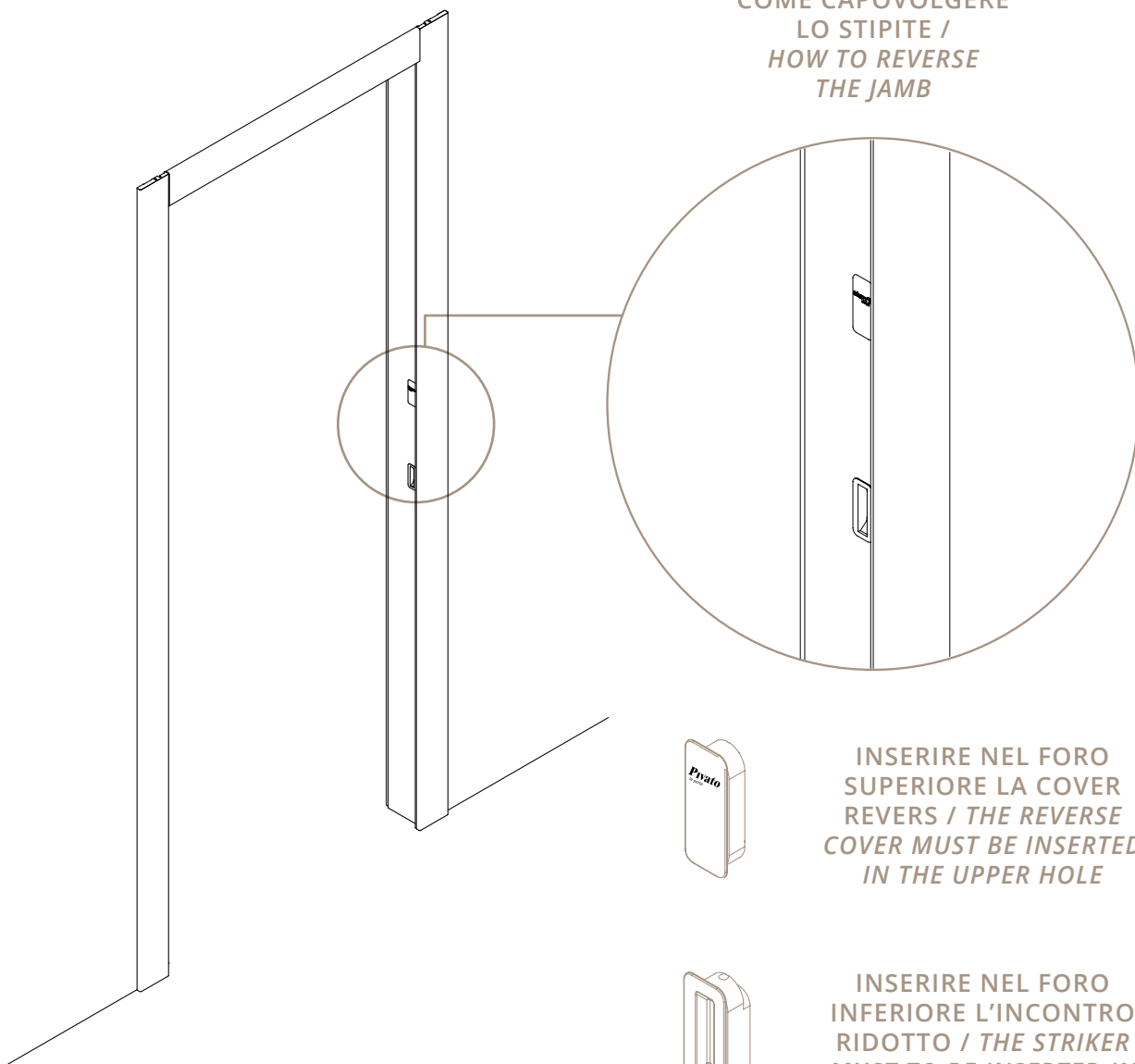

INSERIRE NEL FORO
SUPERIORE LA COVER
REVERS / THE REVERSE
COVER MUST BE INSERTED
IN THE UPPER HOLE

INSERIRE NEL FORO
INFERIORE L'INCONTRO
RIDOTTO / THE STRIKER
MUST TO BE INSERTED IN
THE LOWER HOLE

09 A FILO SUL LATO ESTERNO STANZA / PERFECTLY FLUSH ON THE OUTSIDE ROOM

PRESENTE NELLE
COLLEZIONI:

- Opera50
- Inversa
- Leggera

Piena complanarità tra anta e coprifilo, assicurando alla porta una scenografica vista a filo nel lato esterno stanza, a spingere o a tirare.

The complete coplanarity between door leaf and casing, ensuring the door has a spectacular push or pull flush view on the outside room.



Complanarità
Coplanarity

10

APERTURA A SPINGERE E A TIRARE / PUSH AND PULL OPENING

PRESENTE NELLE
COLLEZIONI:

- Opera50
- Inversa
- Leggera

La porta si apre a spingere di 90° e a tirare di 180°, mantiene la promessa di associare alla comodità e all'utilizzo anche una valenza di design.

The door opens to to push at 90° to pull at 180°, and, ensuring comfort and design.



SPINGERE 90° /
TO PUSH 90°



TIRARE 180° /
TO PULL 180°

GALLERY

MANIGLIE SCAVATE

GUIDA

COLLEZIONI

PLUS

COMPLEMENTI

L'AZIENDA

11 CERNIERA A SCOMPARSA REGISTRABILE / ADJUSTABLE CONCEALED HINGE

PRESENTE NELLE
COLLEZIONI:

- Opera50
- Dinamica
- Unica

- Inversa
- Leggera

La cerniera di una porta Pivato non si vede, non si sente, ma si percepisce nella grande stabilità dell'anta. La cerniera è realizzata in modo da garantire una tenuta perfetta, lunghissima durata e una portata di 50 kg.

La cerniera è registrabile verticalmente, orizzontalmente e in profondità senza rimuovere l'anta.

Colori cover disponibili: grigio satinato, nero. Con Dinamica, Unica e Inversa la cover può anche essere in tinta con l'anta.

A Pivato door hinge cannot be seen nor heard but is perceived in the great stability of the door leaf. These hinges in fact, are made to guarantee a perfect hold, very long durability and a 50 kg capacity to the door.

The possibility to adjust them without removing the door leaf also allows you to always have a perfect hold thanks to the three adjustments: vertical, horizontal and depth.

Available cover finishes: chrome grey, black. *With Dinamica, Unica and Inversa the cover is available also in the same finish of the leaf.*



12

CERNIERA A BILICO INVISIBILE REGISTRABILE / ADJUSTABLE INVISIBLE PIVOT HINGE

PRESENTE NELLE
COLLEZIONI:

- Vivace con stipite su misura e coprifilo telescopico

La cerniera di una porta Pivato non si vede, non si sente, ma si percepisce nella grande stabilità dell'anta. La cerniera è realizzata in acciaio e zama in modo da garantire una tenuta perfetta, lunghissima durata e una portata di 70 kg.

La cerniera è registrabile verticalmente, orizzontalmente e in profondità senza rimuovere l'anta.

Colori cover disponibili: grigio satinato, nero.

A Pivato door hinge cannot be seen nor heard but is perceived in the great stability of the door leaf. These hinges in fact, are made of steel and zamak that guarantees a perfect hold, very long durability and a 70 kg capacity to the door.

The possibility to adjust them without removing the door leaf also allows you to always have a perfect hold thanks to the three adjustments: vertical, horizontal and depth.

Available cover finishes: chrome grey, black.



GALLERY

MANIGLIE SCAVATE

GUIDA

COLLEZIONI

PLUS

COMPLEMENTI

L'AZIENDA

13 SERRATURA E INCONTRO PER SCORREVOLI / LOCK AND STRIKER FOR SLIDING DOORS

PRESENTE NELLE
COLLEZIONI:

- Vivace con stipite su misura e coprifilo telescopico
- Vivace con stipite su misura

- Dinamica
- Unica

La serratura per scorrevoli presenta un doppio gancio con incontro complanare. I due ganci contrapposti che escono dal frontale della serratura ruotano sull'incontro garantendo una chiusura efficace nel tempo.

L'incontro è inserito a filo nello stipite.

The lock for sliding doors has a double hook with a coplanar striker. The two opposing hooks that come out of the lock face rotate on the striker when closing to ensure a better closing over time.

The striker is inserted flush into the jamb.

Colori cover disponibili:
grigio satinato, nero.

Available cover finishes:
chrome grey, black.



14

FUNZIONALITÀ TIRANTI / TIE ROD FUNCTIONALITY

PRESENTE NELLE
COLLEZIONI:

- Vivace con stipite su misura e coprifilo telescopico
- Opera50
- Vivace con stipite su misura
- Dinamica
- Unica
- Inversa
- Leggera

La porta può essere regolata da tiranti interni che permettono all'anta di non deformarsi mai, anche in presenza di sbalzi di temperatura e umidità. La tua porta sarà perfetta per tutta la vita.

The door can be regulated by internal tie-rods that allow door leaf never to deform, even in the presence of temperature and humidity changes. Your door will be perfect for life.



ANTE DA 40 mm:
1 tirante (di serie)

40 mm DOOR LEAF:
1 tie rod (standard)

ANTE DA 56 mm:
- senza tiranti (di serie)
- oltre i 2400 mm di altezza,
ha 2 tiranti (di serie).
Su richiesta è possibile
montare 2 tiranti.

56 mm DOOR LEAF:
- no tie rod (standard)
- over 2400 mm height,
it has 2 tie-rods (standard).
2 tie-rods can be installed on
request.



**ANTA CONCAVA /
CONCAVE DOOR LEAF**
(svitare) / (unscrew)

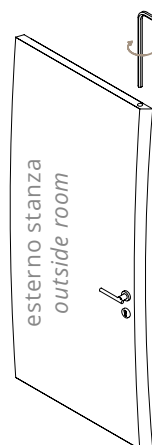

**ANTA CONVESSA /
CONVEX DOOR LEAF**
(avvitare) / (screw)

15 CERNIERA A POMELLA CON APERTURA A 180° / PAUMELLE HINGE WITH 180° OPENING

PRESENTE NELLE
COLLEZIONI:

• Vivace con stipite
su misura

Per la tua porta Vivace Legno puoi scegliere una cerniera a pomella, dal sapore classico. La porta, che si apre a 180°, aderisce perfettamente alle superfici, e permette una personalizzazione estetica che si adatta perfettamente allo stile della tua casa.

Finiture disponibili: ottone lucido, cromo satinato, laccata mazzetta Pivato.

You can choose a classic paumelle hinge for your Vivace Legno door, which has a 180° opening and adheres perfectly to the surfaces allowing aesthetic customization that adapts perfectly to the style of your home.

Available finishes: polished brass, satin chrome, lacquered, Pivato chart.



16 CERNIERA A BILICO CON APERTURA 180° / PIVOT HINGE WITH 180° OPENING

PRESENTE NELLE
COLLEZIONI:

• Vivace con stipite
su misura

La cerniera a bilico è la scelta di chi ama inserire elementi di modernità che valorizzano le linee della porta Vivace. I vantaggi tecnici di Pivato sono garantiti: apertura a 180°, e qualità.

Finiture disponibili: ottone lucido, cromo satinato.

The pivot hinge is the choice of those who like to include elements of modernity that enhance the lines of the Vivace door. The technical advantages of Pivato are guaranteed: 180° opening, and quality.

Available finishes: polished brass, satin chrome.



17

VARIETÀ DEL COPRIFILO / VARIETY OF CASING OPTIONS

PRESENTE NELLE
COLLEZIONI:

• Dinamica

COPRIFILO
CASING

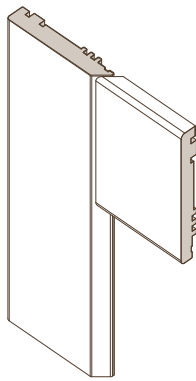

Inclinato
Angled

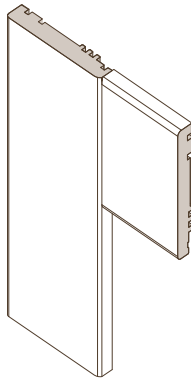

Dritto
Straight

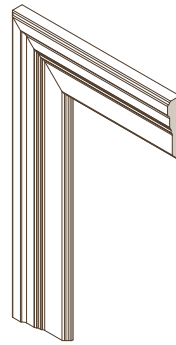

Classico
Classic

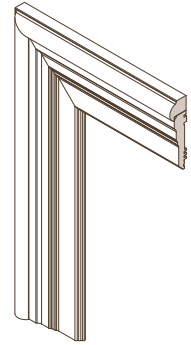

Barocco
Baroque

APERTURA
OPENING

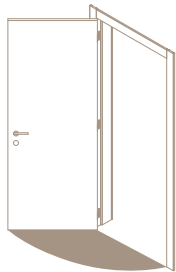

135°



105°



110°

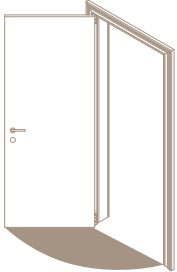

110°

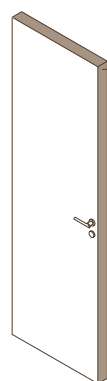

40 mm
spessore anta
door leaf thickness

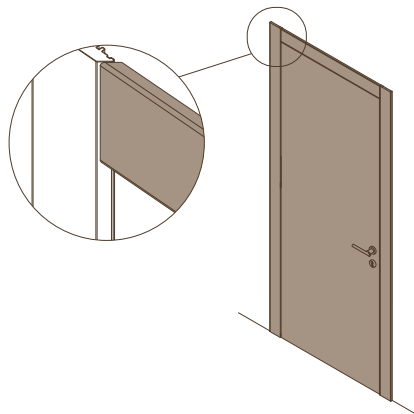

traverso coprifiло
rientrante
the header curves
inward gently

GALLERY

MANIGLIE SCAVATE

GUIDA

COLLEZIONI

PLUS

COMPLEMENTI

L'AZIENDA

18 PROFILO GHOST: 8 VANTAGGI / GHOST PROFILE: 8 ADVANTAGES

PRESENTE NELLE
COLLEZIONI:

• Opera50

Il profilo in alluminio applicato di serie su Opera50 si chiama "Ghost".

A posa terminata, scompare completamente all'interno della struttura senza intaccare l'estetica garantendo numerosi vantaggi senza rinunciare al design.

The aluminum profile is fitted as standard on Opera50. It is called "Ghost".

Once the pose is completed, it disappears completely inside the structure without affecting the design.

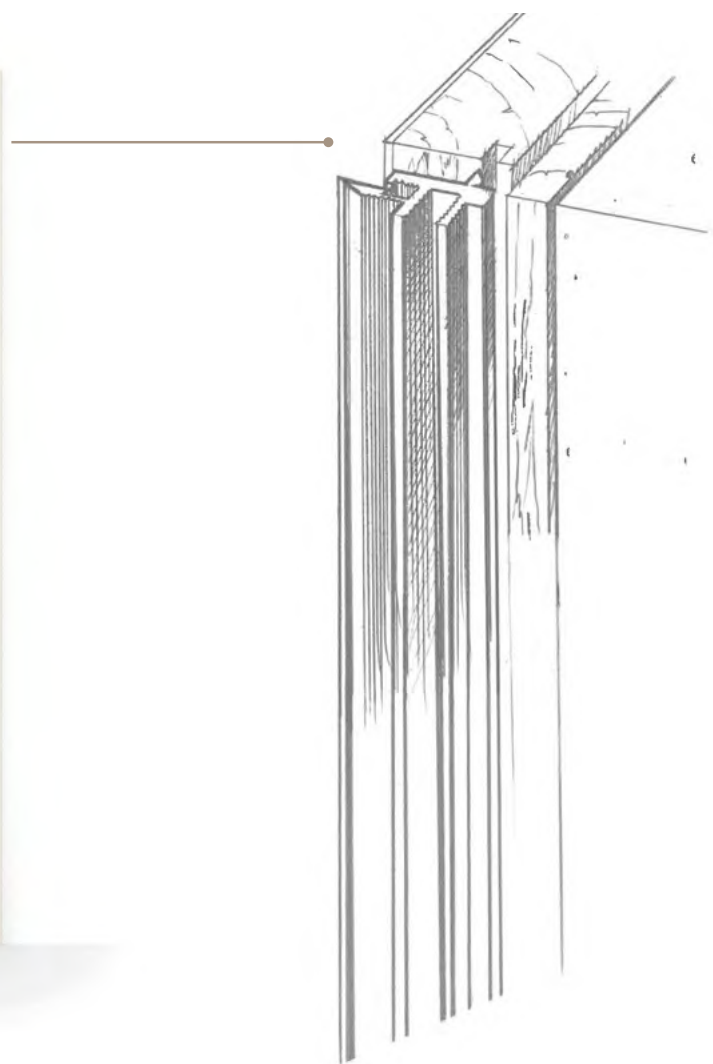



- | | |
|--|---|
| <p>A. FISSATO DA PIVATO SUL BORDO DELLO STIPITE predisposto e fissato con solide viti</p> | <p>A. FIXED BY PIVATO ON THE EDGE OF THE JAMB with a suitable guide seat for fixing with solid screws.</p> |
| <p>B. In caso di violente chiusure garantisce una FORTE TENUTA DELL'ANTA IN BATTUTA</p> | <p>B. In case of violent closings it guarantees STRONG HOLD OF THE DOOR KNOCKER</p> |
| <p>C. Funge da GUIDA PER IL POSATORE NELL'ALLINEARE LO STIPITE ALLA PARETE</p> | <p>C. It acts as A GUIDE FOR THE INSTALLER IN ALIGNING THE JAMB WITH THE WALL</p> |
| <p>D. AGEVOLA IL POSATORE NEL DEFINIRE IL MONTAGGIO E LA PERFETTA REGOLAZIONE DELL'ANTA IN CHIUSURA</p> | <p>D. IT FACILITATES THE INSTALLER TO DEFINE THE MOUNTING AND THE PERFECT ADJUSTMENT OF THE DOOR LEAF</p> |
| <p>E. AGEVOLA IL POSATORE NELLA SCHIUMATURA DELLO STIPITE SENZA COPRIFILO</p> | <p>E. IT FACILITATES THE POSER IN THE FOAMING OF THE JAMB WITHOUT CASING</p> |
| <p>F. Funge da GUIDA PER il posatore per UN CORRETTO FISSAGGIO DEL COPRIFILO</p> | <p>F. It acts as a guide for the installer for a CORRECT FASTENING OF THE CASING</p> |
| <p>G. Garantisce la PERFETTA TENUTA DELLA GUARNIZIONE anche nel traverso superiore, evitando che si stacchi.</p> | <p>G. It guarantees a PERFECT HOLD OF THE GASKET also in the upper crosspiece, preventing it from coming off.</p> |
| <p>H. SCOMPARE TRA STIPITE, GUARNIZIONE E COPRIFILO SENZA RINUNCIARE AL DESIGN</p> | <p>H. IT DISAPPEAR BETWEEN JAMB, GASKET AND CASING WITHOUT GIVING UP DESIGN</p> |

19 BREVETTO INDUSTRIALE EUROPEO DISPOSITIVO DI ANCORAGGIO / EUROPEAN INDUSTRIAL PATENT ANCHORING DEVICE

PRESENTE NELLE
COLLEZIONI:

• Unica

Questo brevetto permette di eseguire una posa in opera in poche e veloci operazioni, che se eseguita bene, rende la porta stabile nel tempo senza cedimenti. Consente inoltre l'installazione di ante particolarmente pesanti senza ricorrere all'impiego di cerniere aggiuntive.

This patent allows for quick and easy installation, which, if carried out correctly, guarantees door stability overtime. Moreover, it allows you to install particularly heavy leaves without using additional hinges.

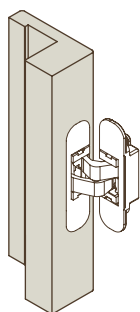

ESTETICA / AESTHETICS

PROFILO UNICO / SINGLE PROFILE

La vera novità studiata da Pivato è il PROFILO UNICO: un pezzo realizzato in abete giuntato a pettine nel quale il coprifilo e lo stipite si fondono insieme garantendo maggiore solidità ed eliminando la giuntura tra gli stessi per un design ancora più minimale e pulito.

Pivato's real innovation consists in the SINGLE PROFILE: a fir finger-jointed piece in which the casing and the jamb merge together guaranteeing increased solidity and eliminating the junction between them in order to have a minimal and clean design.

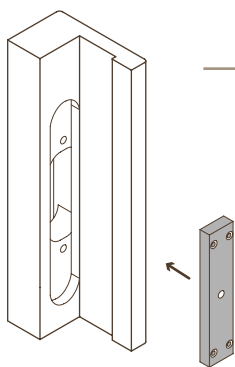

**PROGETTUALITÀ /
DESIGN**

**LAMELLA DI ALLUMINIO /
ALUMINIUM BLADE**

Nella parte posteriore del profilo angolare viene ricavato un alloggiamento in corrispondenza di ogni cerniera, su cui viene inserita una lamella di alluminio che servirà per il fissaggio delle cerniere.

A housing is found in the rear side of the angular profile near the hinge, in which an aluminium blade, used to fasten the hinges, is inserted.

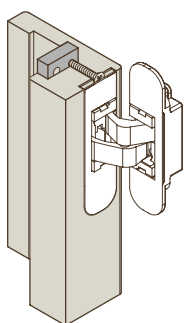

SOLIDITÀ / SOLIDITY

**CERNIERE A SCOMPARSA
REGISTRABILI /
ADJUSTABLE HIDDEN HINGES**

Le cerniere vengono quindi fissate con viti metriche alla lamella di alluminio. L'accorgimento consente di sgravare il peso dell'anta dal profilo unico in legno, scaricandolo sulla lamella di alluminio. Garantisce inoltre l'apertura a 180°.

The hinges are fastened to the aluminium blade with metric screws. This allows you to move the leaf weight from the wooden single profile to the aluminium blade. It also guarantees 180° opening.

**GARANZIA /
WARRANTY**

**STADIA DI ALLUMINIO /
ALUMINIUM PROFILE**

La porta viene ancorata ad una stadia di alluminio precedentemente fissata al muro, falso telaio o cartongesso.

The door is anchored to an aluminium profile, which is fastened to the wall, basic door frame, or plasterboard. The hingeblade-profile mechanical fixing completes the operation.

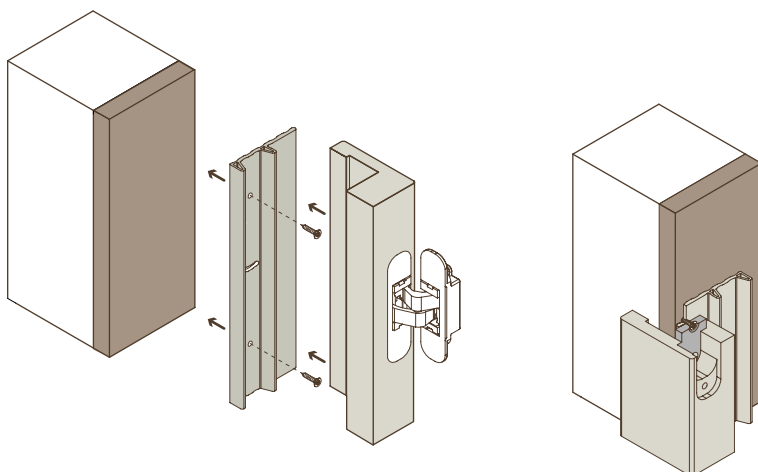

20 FILOMURO CON NUCLEO A SCOMPARSA / FLUSH-TO-WALL DOOR WITH RETRACTABLE CORE

PRESENTE NELLE
COLLEZIONI:

• Leggera

Mancando lo stipite, la filomuro Pivato si affida ad un nucleo ad alta rigidità torsionale, che garantisce alla porta una presa sul muro (o sul cartongesso) tale da sostenere l'anta e permettere la stabilità che Pivato assicura a tutti i suoi prodotti.

Il nucleo viene proposto in 2 varianti: bianco e alluminio verniciabile.

As it has no jamb, Pivato's flush-to-wall door relies on a core with high torsional rigidity that ensures the door such a grip on the wall (or plasterboard) so that it supports the door leaf and enables the stability that Pivato ensures in all its products.

The core is proposed in 2 variations: paintable in white and aluminium.

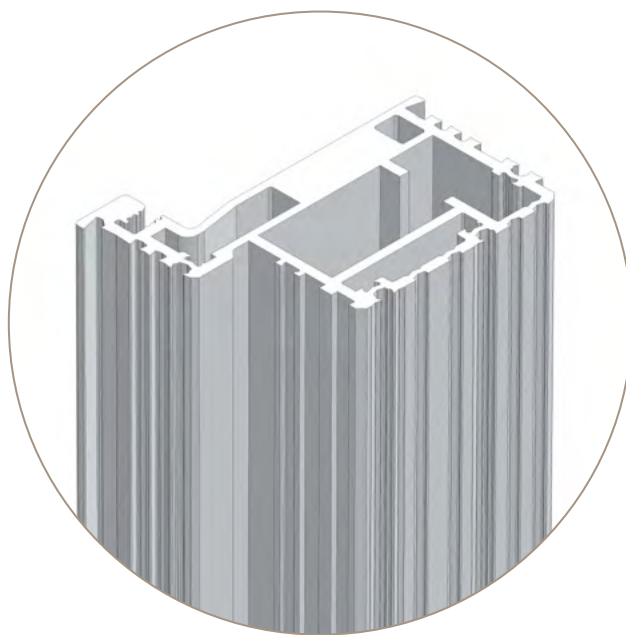
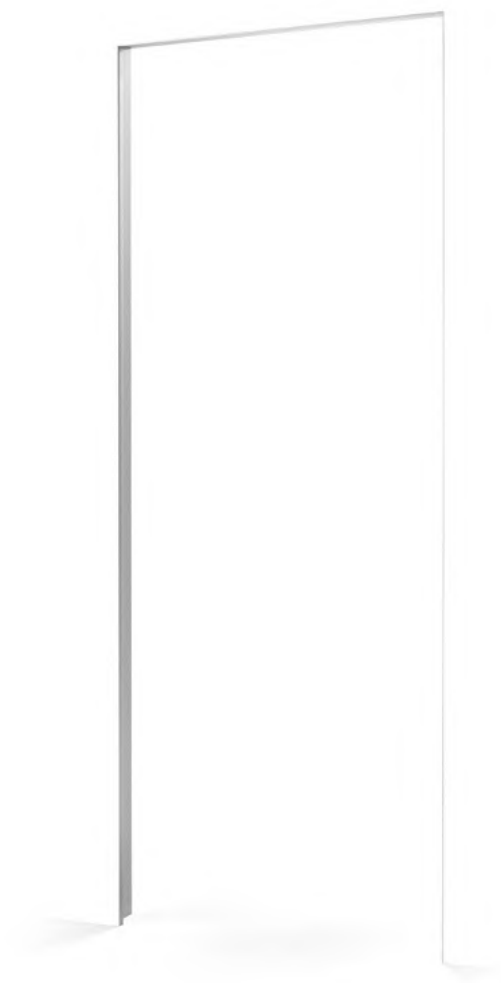

alluminio verniciabile
paintable aluminium



bianco
white



SOLUZIONI PERSONALIZZATE / CUSTOM-MADE SOLUTIONS

Leggera apre ad un mondo di opportunità e di scelte non solo estetiche ma anche tecniche.

Scegliere Leggera significa apprezzare la tecnologia e la ricercatezza formale che Pivato riserva a tutti i propri prodotti.

The Leggera model opens up to a world of aesthetic and technical opportunities and choices.

Choosing Leggera means appreciating the technology and refinement of the Pivato products.

Leggera può essere tinteggiata o rivestita con carta da parati della stessa finitura della parete.

Leggera can be painted or lined with wallpaper.

In questa conformazione l'anta è perfettamente allineata e integrata alla parete, visivamente si ottiene un risultato omogeneo.

In this configuration, the door is perfectly aligned and integrated to the wall; the final visual result is seamless.



anta a spingere
push leaf

anta a tirare
pull leaf

battiscopa a filo su anta e parete
skirting boards on door leaf and wall

Complementi *Accessories*

MANIGLIE AD INCASSO

BATTISCOPIA

Maniglie ad incasso / *Built-in handles*

Molto spesso la maniglia è un elemento caratterizzante della porta: ne arricchisce la personalità, ne richiama il contatto, ne definisce lo stile

Scegli tra la selezione che Pivato ti offre, sapendo che puoi contare su materiali di altissima qualità e, anche in questo caso, su una ricerca volta a soddisfare non solo il tuo gusto in tema di estetica e design, ma anche il tuo piacere in termini di utilizzo.

Very often the handle is a characterizing element of the door. It enriches its personality, recalls its contact and defines its style.

Choose from the selection that Pivato offers you, knowing that you can count on the highest quality materials and, in this case, on research aimed at satisfying not only your taste in terms of aesthetics and design, but also your pleasure in terms of use.

Quadro

Applicabilità: cabina armadio, scorrevole esterno ed interno muro.

Feasibility: walk-in closet wardrobe external and internal sliding door.



Spirale

Applicabilità: scorrevole esterno ed interno muro.

Feasibility: external and internal sliding door.

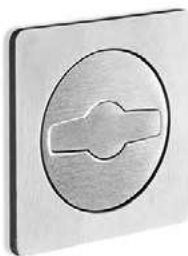

Uno.Zero by Pivato

È il risultato della ricerca Pivato: ergonomia, prensilità, forme essenziali sono valori che Uno.Zero esprime.

It is the result of Pivato's search: ergonomics, tactility, and essential shapes are values that Uno.Zero expresses.

PLACCA AD INCASSO / BUILT-IN PLATE

Applicabilità: porta battente con apertura silenzioso, cabina armadio, scorrevole esterno e interno muro.

Colori disponibili: bianco, cromo satinato, nero.

Feasibility: hinged door with noiseless opening, walk-in closet door, external and internal sliding door.

Available colours: white, satin chrome, black.



PLACCA AD INCASSO CON CHIUSURA / BUILT-IN PLATE WITH LOCK

Applicabilità: porta battente con apertura silenzioso, scorrevole esterno e interno muro.

Colori disponibili: bianco, cromo satinato, nero.

Feasibility: hinged door with noiseless opening, external and internal sliding door.

Available colours: white, satin chrome, black.



Mistero

Applicabilità: scorrevole esterno ed interno muro.

Feasibility: external and internal sliding door.



Rondò

PLACCA AD INCASSO / BUILT-IN PLATE

Applicabilità: scorrevole esterno e interno muro.
Colori disponibili: bianco, cromo satinato, nero.

Feasibility: external and internal sliding door.
Available colours: white, satin chrome, black.



PLACCA AD INCASSO CON CHIUSURA / BUILT-IN PLATE WITH LOCK

Applicabilità: scorrevole esterno e interno muro.
Colori disponibili: bianco, cromo satinato, nero.

Feasibility: external and internal sliding door.
Available colours: white, satin chrome, black.



Enigma

PLACCA AD INCASSO / BUILT-IN PLATE

Applicabilità: scorrevole esterno e interno muro.
Colori disponibili: bianco, cromo satinato, nero.

Feasibility: external and internal sliding door.
Available colours: white, satin chrome, black.



PLACCA AD INCASSO CON CHIUSURA / BUILT-IN PLATE WITH LOCK

Applicabilità: scorrevole esterno e interno muro.
Colori disponibili: bianco, cromo satinato, nero.

Feasibility: external and internal sliding door.
Available colours: white, satin chrome, black.



Luce

Applicabilità: cabina armadio.

Feasibility: walk-in closet door.



Dado

Applicabilità: cabina armadio.

Feasibility: walk-in closet door.



Per altre finiture, consultare il listino.
For other finishes, see price list.

Battiscopa / Baseboards



DRITTO 13X90 mm STRAIGHT 13X90 mm

Supporto in multistrato di pioppo.

Impiallacciatura in legno (sia per laccati che per legni)

Legni: rovere bianco spazzolato, rovere grigio spazzolato, canaletto spazzolato, canaletto tabacco spazzolato, olmo brandy spazzolato.

Laccati: frassino spazzolato, yellow pine spazzolato, opaco.

Poplar wood multilayer support.

Wood veneer (both for lacquered and wood products)

Wood: brushed white oak, brushed gray oak, brushed canaletto walnut, brushed tobacco canaletto walnut, brushed brandy elm.

Lacquered: brushed ash, brushed yellow pine, matt.

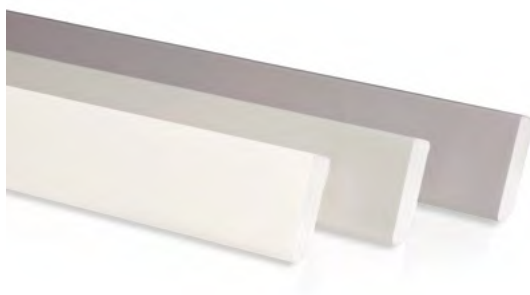

DRITTO 13X40 mm STRAIGHT 13X40 mm

Supporto in multistrato di pioppo.

Impiallacciatura in legno (per laccati)

Laccato: frassino laccato spazzolato, opaco.

Poplar wood multilayer support.

Wood veneer (both for lacquered options)

Lacquered: brushed lacquered ash wood, matt.



TONDO 10X70 mm
CURVED 10X70 mm

Supporto in multistrato di pioppo.
Impiallacciatura in legno (sia per laccati
che per legni)

Laccati: laccato opaco, frassino spazzolato.

*Poplar wood multilayer support.
Wood veneer (both for lacquered and
wood options)*

Lacquered: matt lacquered, brushed ash.

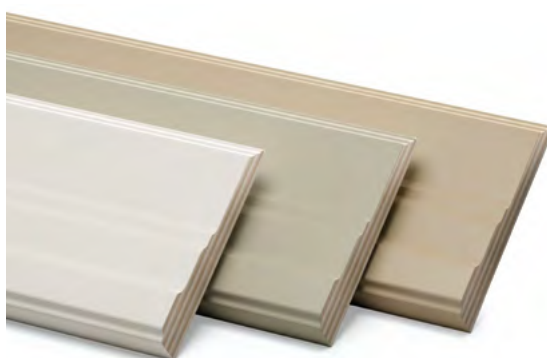

CLASSICO 25X100 mm
CLASSIC 25X100 mm

Supporto in multistrato di pioppo.
Impiallacciatura in legno (per laccati)

Laccato: opaco.

*Poplar wood multilayer support.
Wood veneer (both for lacquered options)*

Lacquered: matt.

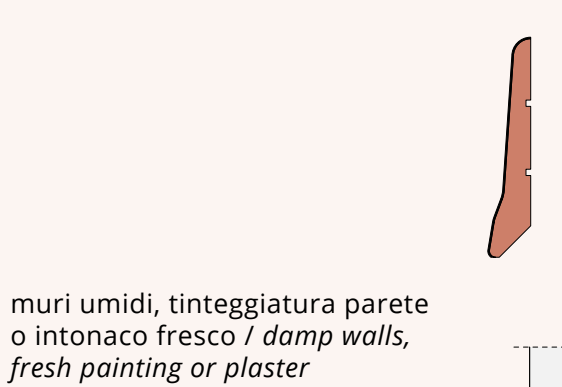

muri umidi, tinteggiatura parete o intonaco fresco / damp walls, fresh painting or plaster

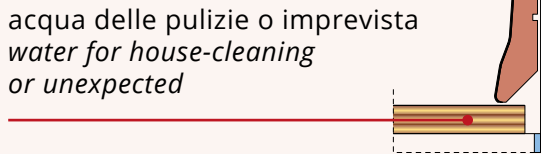

acqua delle pulizie o imprevista / water for house-cleaning or unexpected

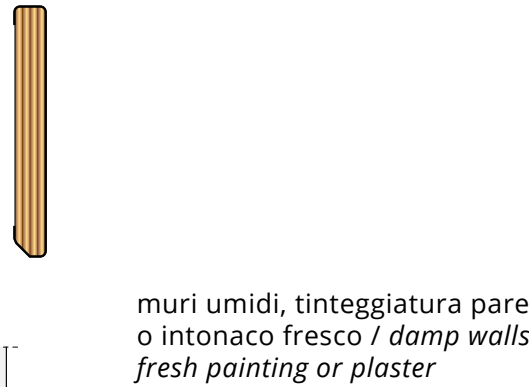

muri umidi, tinteggiatura parete o intonaco fresco / damp walls, fresh painting or plaster

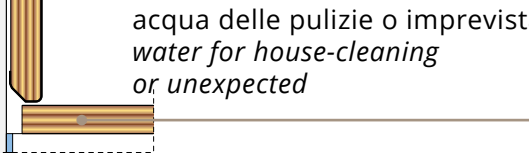

acqua delle pulizie o imprevista / water for house-cleaning or unexpected

supporto in MDF che può deformarsi / the support in medium density fibreboard can be deformed

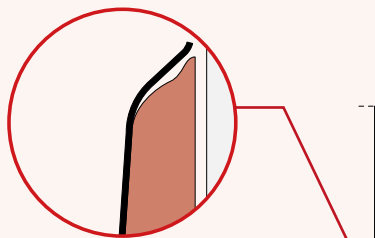

tranciato di rivestimento solo sulla faccia a vista che può scollarsi / the veneer covers the support only in the front side: it can unglue

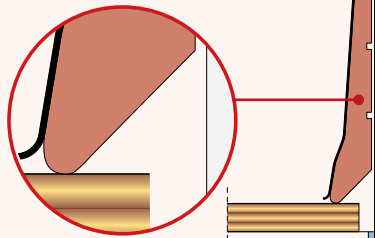

supporto in multistrato di pioppo: non si deforma e resiste a tutto / poplar multy-ply support: non deformable and fully resistant

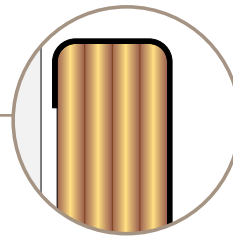

tranciato di rivestimento anche dietro il supporto: non si scolla mai / the veneer covers the support also in the back: it doesn't unglue

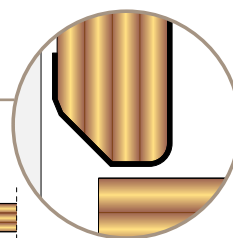



IL RIVESTIMENTO THE CLADDING

Il rivestimento garantisce un elemento di naturalità e di eccellenza alla vista, ma non è solamente un bell'elemento di design. L'utilizzo di materiale di eccellenza per i nostri battiscopa, garantisce una protezione contro umidità, versamenti di liquidi e tinteggiature, proteggendo l'interno in multistrato di pioppo.

Cladding provides an element of naturalness and excellence to the eye, but it is not just a beautiful design element. The use of top-quality material for our baseboards guarantees protection against moisture, liquid spills and paintwork, protecting the poplar plywood interior.

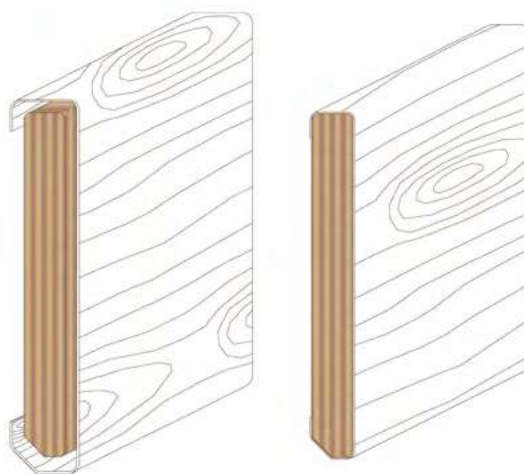

GALLERY

MANIGLIE SCAVATE

GUIDA

COLLEZIONI

PLUS

COMPLEMENTI
Battiscopa

L'AZIENDA

L' Azienda
The Company

50 anni di storia 50 years of history

50
1969-2019

La storia di Pivato è la storia dell'alta artigianalità made in Italy. Dal 1969, quando Ottorino Pivato aprì la falegnameria Pivato nel garage di casa, le nostre porte hanno sempre avuto un elemento in comune: la passione della mano che le costruisce.

Con il passare del tempo, alla cura artigianale si è affiancata la ricerca minuziosa della qualità e del gusto che oggi potete trovare in tutte le nostre porte.

The story of Pivato is the history of Made in Italy high craftsmanship. Since 1969, when Ottorino Pivato opened the Pivato joinery in his garage, our doors have always had one thing in common: the passion of the hand that manufactures them.

With the passage of time, craftsmanship has been accompanied by the meticulous search for quality and taste that you can find today in all our doors.

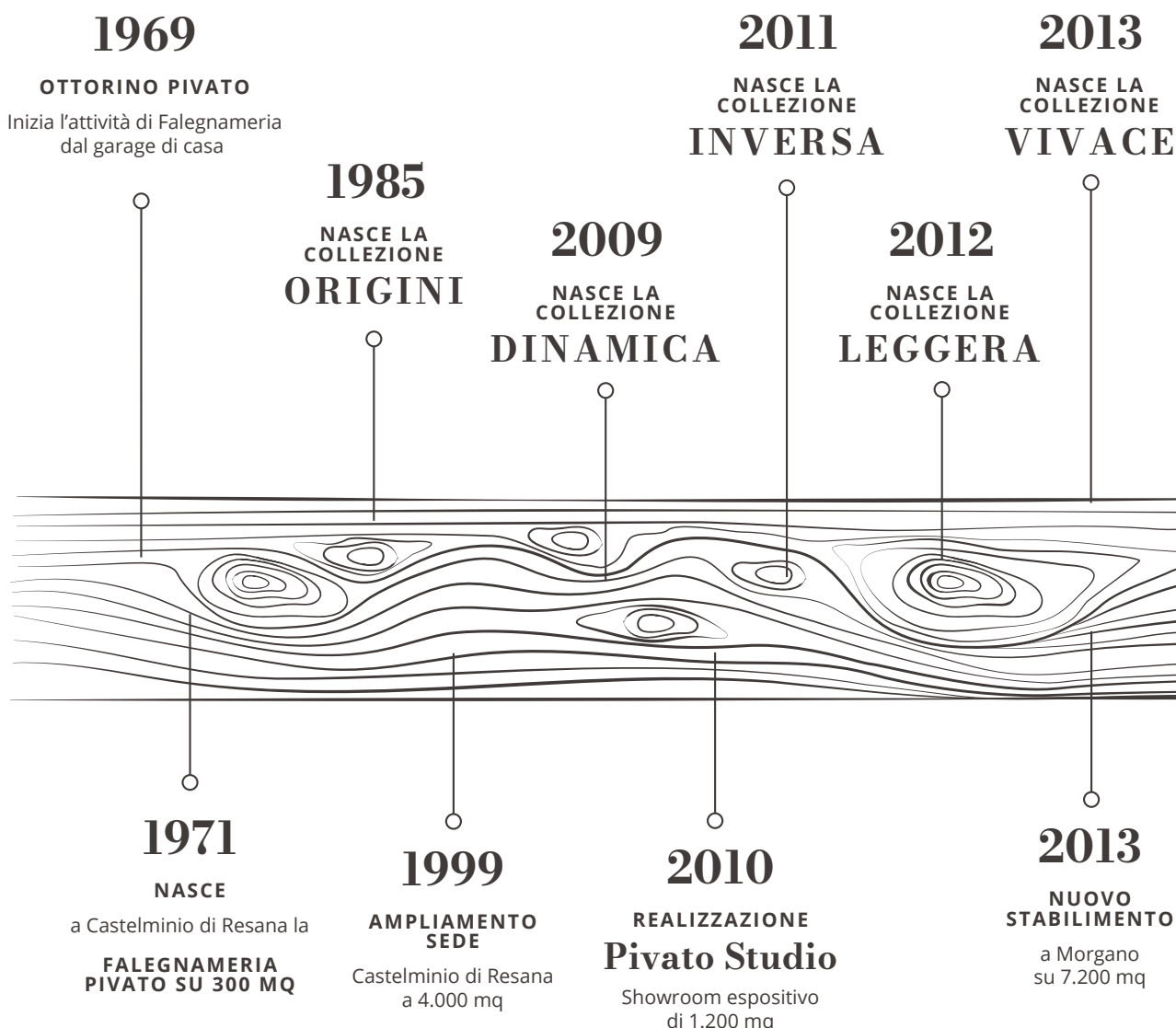

Il laboratorio divenne falegnameria, la falegnameria divenne una piccola azienda e oggi, cinquant'anni dopo, Pivato è una vera e propria piccola industria dell'artigianalità, capace di assicurare la solidità e la qualità del prodotto legato al suo nome. Il nostro futuro?

Come da sempre, sarà legato alla costante ricerca dello stile e del design, ad un'accurata selezione delle materie prime per valorizzare al massimo la qualità delle porte realizzate da personale altamente qualificato. E tra altri 50 anni le nostre porte di oggi saranno ancora lì a raccontare una storia di passione ed eccellenza: quella di Pivato, dal 1969.

The workshop became a joinery, the joinery became a small company and today, 50 years later, Pivato is a real small craftsmanship industry, able to ensure the solidity and quality of the product linked to its name.

Our future? It will be like always, linked to the constant search for style and design, to the accurate selection of raw materials to maximize the quality of the doors made by highly-qualified staff.

And in another 50 years, our doors will still be there to tell a story of passion and excellence: that of Pivato, since 1969.

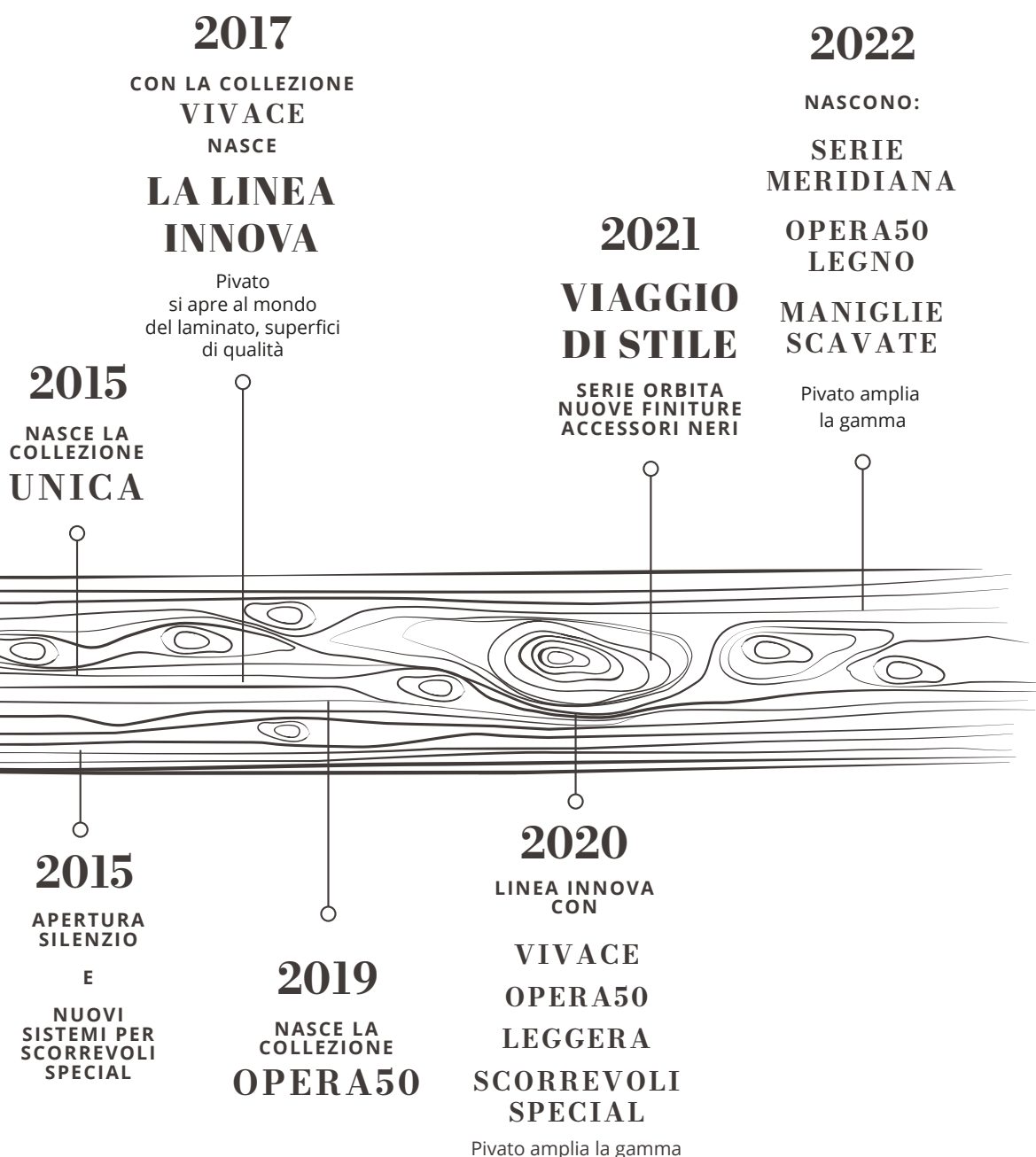

Made in Italy



Mappe
Maps



GALLERY

MANIGLIE SCAVATE

GUIDA

COLLEZIONI

PLUS

COMPLEMENTI

L'AZIENDA

Sedi Pivato

Pivato headquarters

- 1. Sede produttiva** a Castelminio (Treviso)
Production site in Castelminio (Treviso)
- 2. Sede espositiva Pivato Studio** a Resana (Treviso)
Exhibition site Pivato Studio in Resana (Treviso)
- 3. Sede produttiva e amministrativa** a Morgano (Treviso)
Production site and administrative headquarter in Morgano (Treviso)





GALLERY

MANIGLIE SCAVATE

GUIDA

COLLEZIONI

PLUS

COMPLEMENTI

L'AZIENDA

Inserto illustrato

Illustrated insert

A cura dell'illustratrice:
By the illustrator:

M.ELA
(MICHELA ZALUNARDO)

PRENDENDO SPUNTO
DALLE ORIGINI...

Due curiosi personaggi
per raccontare le nostre
porte in modo nuovo

Geppetto e Pinocchio, che tutti conosciamo, sono i celebri personaggi del romanzo per ragazzi "Le avventure di Pinocchio" scritto da Carlo Lorenzini (detto Collodi) nel 1881.

Attraverso questi due personaggi racconteremo il nostro mestiere a chi si avvicina al mondo di Pivato porte per la prima volta o a chi lo conosce già ma potrebbe scoprire qualcosa di nuovo.

Questi personaggi, reinterpretati dall'illustratrice Michela Zalunardo (in arte M.ELA), **spiegheranno alcune caratteristiche delle porte Pivato e dell'operato dell'azienda stessa, con simpatia ma anche grande senso pratico.** Sarà per noi un modo di raccontare il valore del nostro lavoro con un linguaggio semplice ed intuitivo.

TAKING A CUE
FROM THE ORIGINS...

*Two curious
characters to tell our
doors in a new way*

Geppetto and Pinocchio, whom we all know, are the famous characters of the children's novel "The Adventures of Pinocchio" written by Carlo Lorenzini (known as Collodi) in 1881.

Through these two characters we will explain our profession to those who approach the world of Pivato porte for the first time or to those who already know it but could discover something new.

These characters, reinterpreted by the illustrator Michela Zalunardo (aka M.ELA), will explain some characteristics of the Pivato doors and the work of the company itself with sympathy, but also a great practical sense. It will be a way for us to explain the value of our work with a simple and intuitive language.

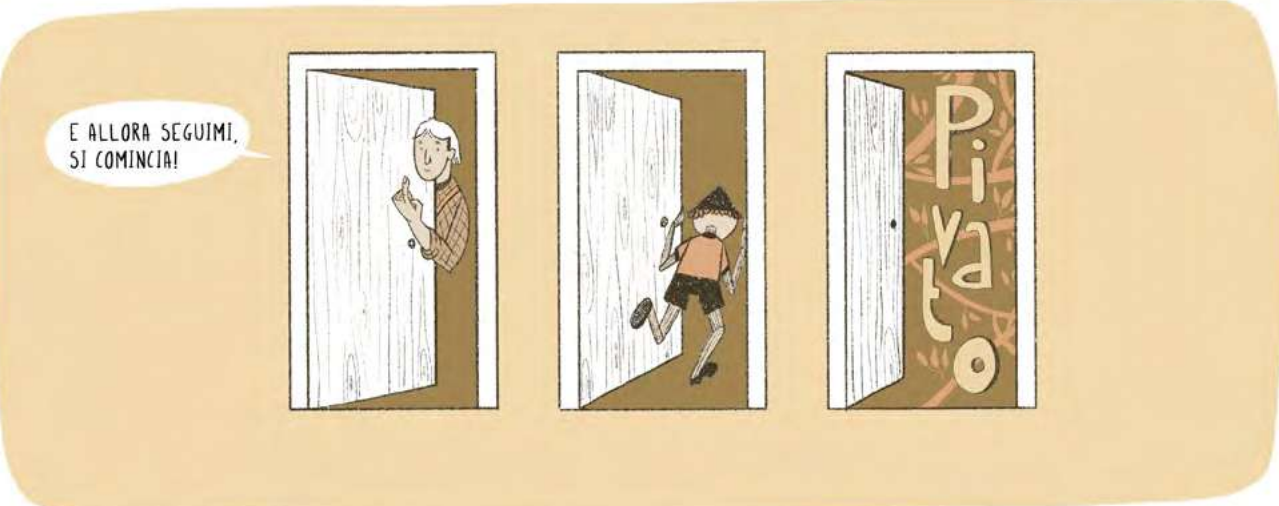
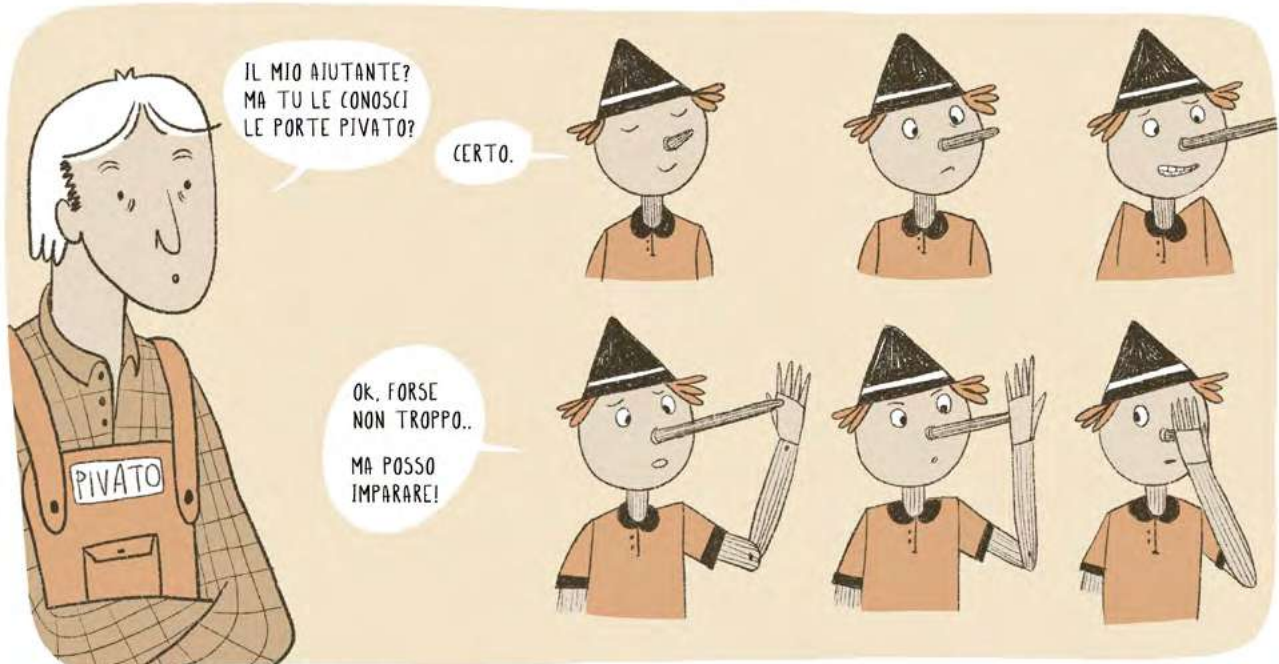

GUIDA ALLA SCELTA

5 PASSI

per scegliere la tua porta

1 STILE

COME VUOI CHE SIA FATTA LA TUA ANTA?

A seconda delle lavorazioni dell'anta ci sono diversi STILI.

Questi sono alcuni esempi. Più avanti vedremo tutti gli stili nel dettaglio.

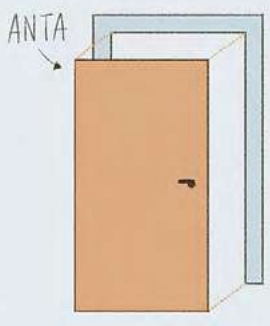

2 MODELLO

CHE VARIANTE VUOI?

Ogni stile offre diverse varianti, i MODELLI.

Ogni modello è denominato da un codice numerico!

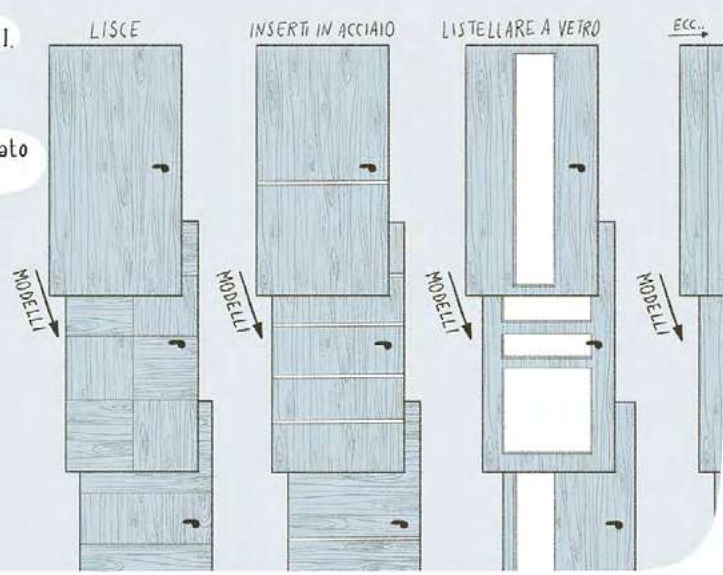

3 FINITURE E COLORI

CHE FINITURA E COLORE VUOI?



Un'ampia scelta per tutti i gusti!

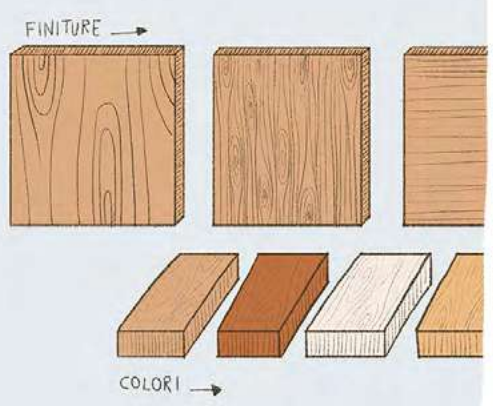

4 APERTURA

COME VUOI CHE SI APRA?



Scegli l'apertura più adatta alle tue esigenze!



5 COLLEZIONE

COME VUOI CHE SIA FATTA LA "CORNICE" DELLA TUA PORTA?



A seconda di come è fatta la "cornice" abbiamo diverse COLLEZIONI.



In seguito vedremo tutte le collezioni!

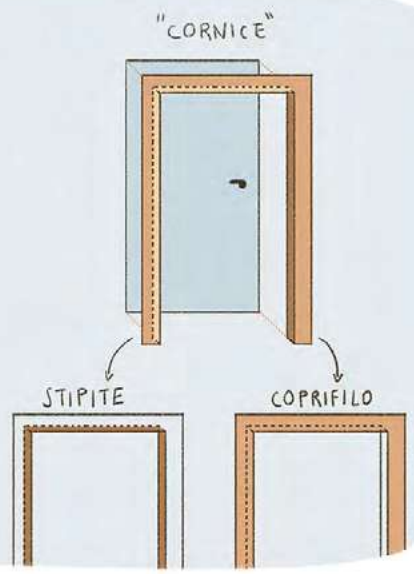

STILI



LISCE



INSERTI in ACCIAIO



PANTOGRAFATE



INCISIONE



BASSORILIEVO



BASSORILIEVO e INCISIONE



LISTELLARE A VETRO



LISTELLARE CIECHE



MODULAR



LISCE

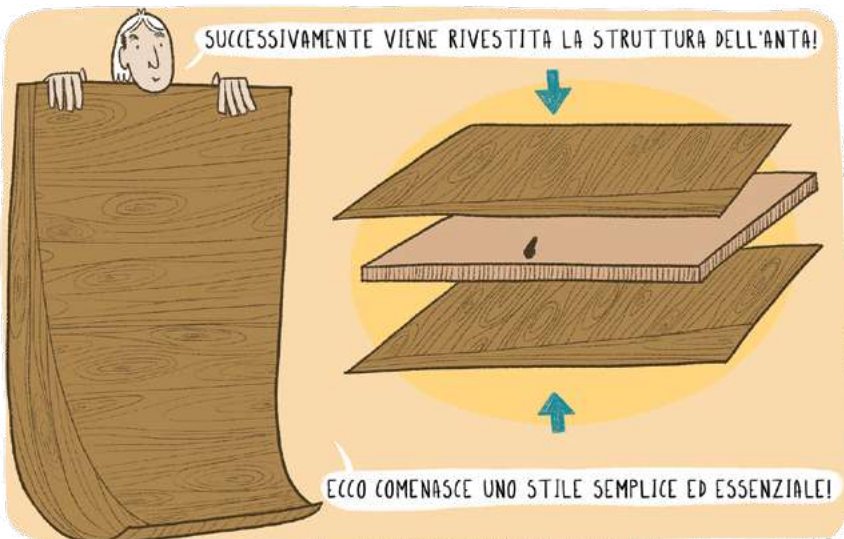

INCISIONE



BASSORILIEVO



PANTOGRAFATE

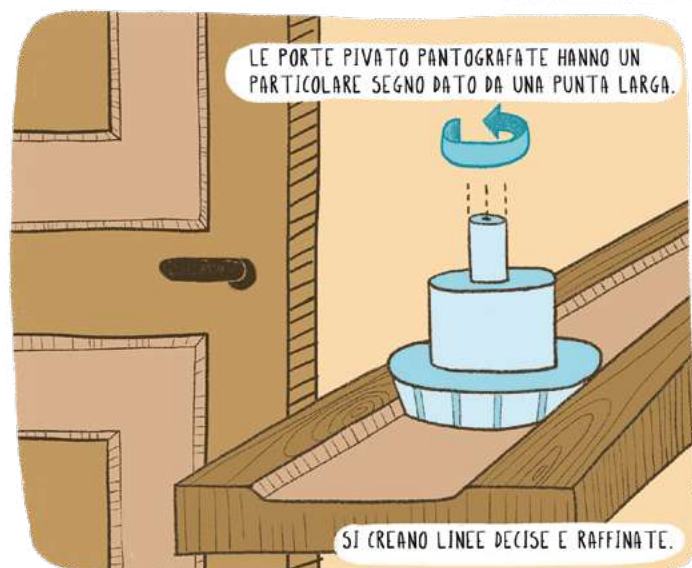

MODELLI

lisce



MODELLI

inserti in acciaio



MODELLI

incisione

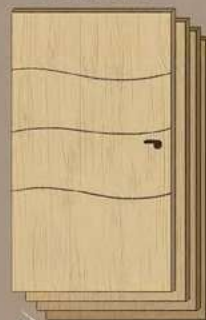

MODELLI

bassorilievo



MODELLI

bassorilievo e incisione



MODELLI

pantografate



MODELLI

modular



MODELLI

listellare a vetro



MODELLI

listellare cieche



SCELGO QUESTO MODELLO!

FINITURE e COLORI



APERTURE

BATTENTE



CABINA ARMADIO



A LIBRO



ROTOTRASLANTE



SCORREVOLE ESTERNO MURO



SCORREVOLE INTERNO MURO



COLLEZIONI



IN BASE A COME È FATTA
QUESTA "CORNICE" ABBIAMO
SEI COLLEZIONI:

- UNICA
- LEGGERA
- INVERSA
- VIVACE
- DINAMICA
- OPERA 50





Pivato

le porte

Sede Produttiva

Via Trieste, 9 - 31023 Castelminio di Resana (TV) - Italy
T. +39 0423 484043

Sede Produttiva e Amministrativa

Via Settimo, 26 - 31050 Morgano (TV) - Italy

Sede Espositiva

Pivato Studio - Via Fornace, 53 - 31023 Castelminio di Resana (TV) - Italy

CREDITS

Agency: mementocomunicazione.it

Rendering: imaginecg.it

Printing: gruppologo.it

Printed in: Gennaio 2023 / January 2023

Pivato
le porte

Sede Produttiva

Via Trieste, 9 - 31023 Castelminio di Resana (TV) - Italy
T. +39 0423 484043

Sede Produttiva e Amministrativa

Via Settimo, 26 - 31050 Morgano (TV) - Italy

Sede Espositiva

Pivato Studio - Via Fornace, 53 - 31023 Castelminio di Resana (TV) - Italy